

# 7100

## ACCENT FIXTURE

### SPECIFICATIONS

**FIXTURE:** PRIMARY 356 CAST ALUMINUM CONSTRUCTION. FIXTURE SUPPLIED WITH 1/2" NPT CAST ALUMINUM ADJUSTABLE KNUCKLE.

**LENS:** CLEAR CONVEX, 1/4" TEMPERED GLASS.

**GASKETING:** LENS GASKET-"A" SCALE HIGH TEMPERATURE SILICONE.  
SPLICE/BALLAST COMPARTMENT GASKET-60 S.D.H. "A" SCALE-DIE CUT NEOPRENE.

**LAMP HOLDER:** 4KV PORCELAIN MEDIUM BASE. PAR 56-MOGUL END PRONG.

**LAMP:** (BY OTHERS)

**BALLAST:** HIGH POWER FACTOR AUTOTRANSFORMER -20°F STARTING TEMPERATURE.

**FASTENERS:** 18-8 STAINLESS STEEL.

**WIRING COMPONENTS:** 14 GAUGE 200°C TEMPERATURE RATING. 1/4"-20 GROUNDING LUG PROVIDED.

**SPLICE BOX:** CONSTRUCTED OF PRIMARY 356 CAST ALUMINUM. ONE (1) 1/2" NPT MOUNTING ENTRY PROVIDED AT TOP, AND TWO (2) 3/4" NPT CONDUIT ENTRIES AT BOTTOM.  
(INC MODEL)  
(OPTIONAL)

**BALLAST BOX:** CONSTRUCTED OF PRIMARY 356 CAST ALUMINUM. ONE (1) 1/2" NPT MOUNTING ENTRY PROVIDED AT TOP OF THE SPLICE COMPARTMENT, TWO (2) 3/4" NPT CONDUIT ENTRIES PROVIDED AT BOTTOM. BALLAST COMPARTMENT ISOLATED FROM SPLICE COMPARTMENT BY AN ANTI-WICKING CHAMBER WHICH IS SEALED WITH AN EPOXY BASED RESIN.

**FINISH:** 3 MILS TGIC THERMOSET EPOXY POWDER COATING.

**TESTING:** FACTORY UNDER WATER POROSITY PRESSURE TEST TO 10 P.S.I. ON BALLAST BOX.

FACTORY CERTIFIED LEAK PREVENTION TEST ON 100% OF ALL FINISHED GOODS.

ETL LISTED FOR WET LOCATION AND CONCRETE POUR APPLICATIONS.

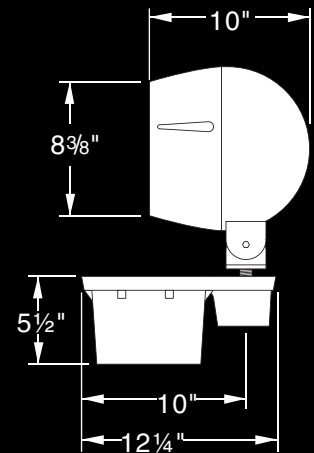
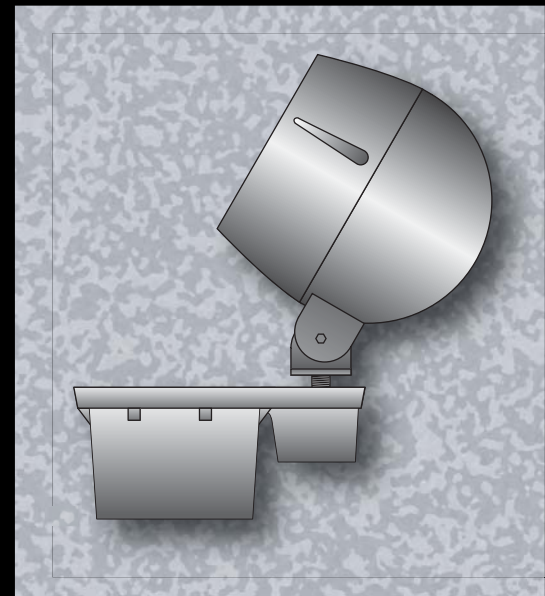

7100 (H.I.D.)

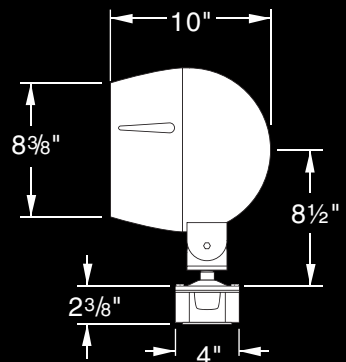

7100 (INC.)

# 7100

ACCENT FIXTURE

TYPE: \_\_\_\_\_

## 7100 (H.I.D.)

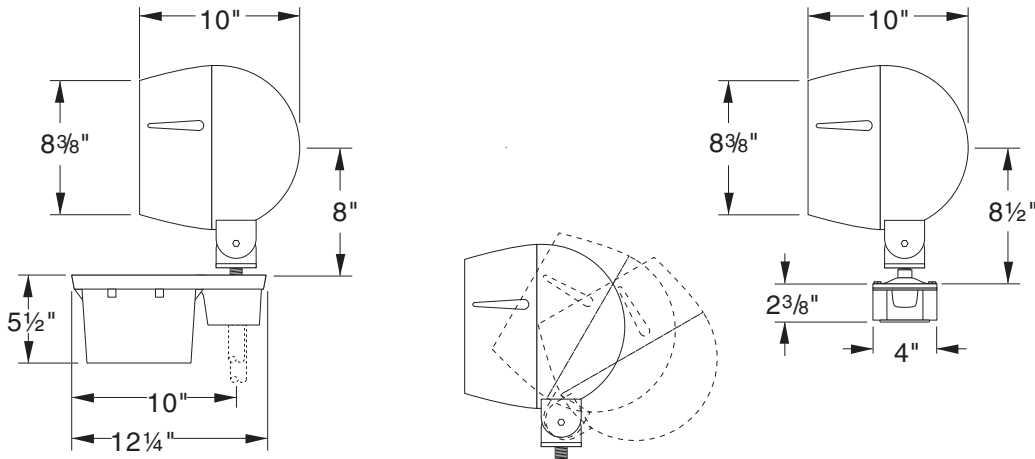

Field Adjustable to 60°

## ORDERING INFORMATION

MODEL NO.:  
7100

PART NUMBERS

FINISH

MODEL NO.:

### PART NUMBERS

### FINISH

7  
1  
0  
0

- 7100-INC., PAR-38/R40, 300W
- 7100-INC., PAR 56, 500W
- 7100-MV 100, PAR 38, 100W
- 7100-MV 175, R-40, 175W
- 7100-HPS-35, E-17, 35W
- 7100-HPS-50, E-17, 50W
- 7100-HPS-70, E-17, 70W
- 7100-HPS-100, E-17, 100W
- 7100-HPS-150, E-17, 150W
- 7100-MH 35, PAR 30, 35W
- 7100-MH 50, E-17, 50W
- 7100-MH-70, R-40, 70W
- 7100-MH-100, R-40, 100W
- 7100-MH-150, PAR 38, 150W
- 7100-MH 175, R-40, 175W

- DARK BRONZE. . . . .DB  
(STANDARD COLOR)
- BLACK. . . . .BK
- WHITE. . . . .WT
- ALUMINUM. . . . .AL

US ARCHITECTURAL. RESERVES THE RIGHT TO MAKE CONTINUED PRODUCT DESIGN AND CONSTRUCTION IMPROVEMENTS WHICH MAY AFFECT THE PRODUCT ILLUSTRATED