

7523

ACCENT FIXTURE

SPECIFICATIONS

FIXTURE: PRIMARY 356 CAST ALUMINUM CONSTRUCTION. FIXTURE SUPPLIED WITH 1/2" NPT CAST ALUMINUM ADJUSTABLE KNUCKLE.

LENS: CLEAR CONVEX, 1/4" TEMPERED GLASS.

GASKETING: **LENS GASKET-**50 S.D.H. "A" SCALE HIGH TEMPERATURE EXTRUDED SILICONE.
SPLICE/BALLAST COMPARTMENT GASKET-60 S.D.H. "A" SCALE-DIE CUT NEOPRENE.

LAMP HOLDER: 4KV PORCELAIN MEDIUM BASE.

LAMP: (BY OTHERS)

BALLAST: HIGH POWER FACTOR AUTOTRANSFORMER
-20° F STARTING TEMPERATURE.

FASTENERS: 18-8 STAINLESS STEEL.

WIRING COMPONENTS: 14 GAUGE 200°C TEMPERATURE RATING.
1/4"-20 GROUNDING LUG PROVIDED.

SPLICE BOX: CONSTRUCTED OF PRIMARY 356 CAST ALUMINUM. ONE (1) 1/2" NPT MOUNTING ENTRY PROVIDED AT TOP, AND TWO (2) 3/4" NPT CONDUIT ENTRIES AT BOTTOM.
(INC MODEL)
(OPTIONAL)

BALLAST BOX: CONSTRUCTED OF PRIMARY 356 CAST ALUMINUM. ONE (1) 1/2" NPT MOUNTING ENTRY PROVIDED AT TOP OF THE SPLICE COMPARTMENT, TWO (2) 3/4" NPT CONDUIT ENTRIES PROVIDED AT BOTTOM. BALLAST COMPARTMENT ISOLATED FROM SPLICE COMPARTMENT BY AN ANTI-WICKING CHAMBER WHICH IS SEALED WITH AN EPOXY BASED RESIN.
(HID MODEL)

FINISH: 3 MILS TGIC THERMOSET EPOXY POWDER COATING.

TESTING: FACTORY UNDER WATER POROSITY PRESSURE TEST TO 10 P.S.I.

FACTORY CERTIFIED LEAK PREVENTION TEST ON 100% OF ALL FINISHED GOODS.

ETL LISTED FOR WET LOCATION AND CONCRETE POUR APPLICATIONS.

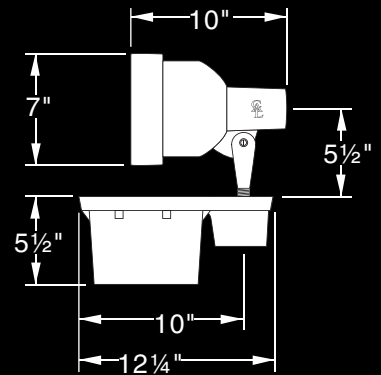
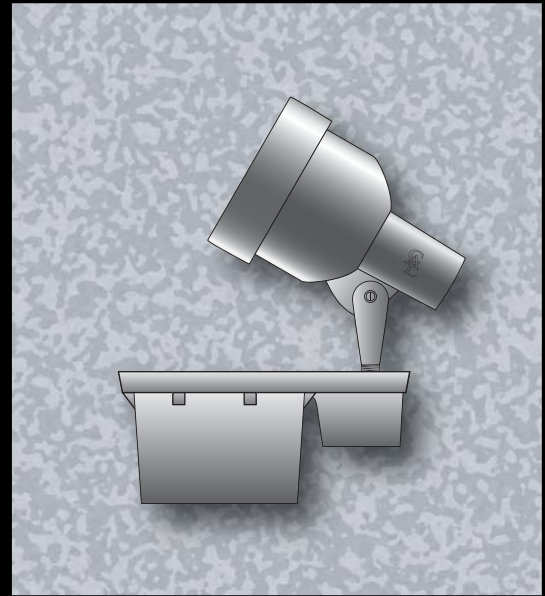

7523 (H.I.D.)

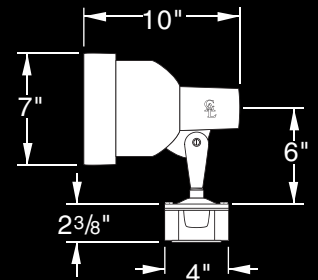

7523 (INC.)



7523

ACCENT FIXTURE

TYPE: _____

7523 (H.I.D.)

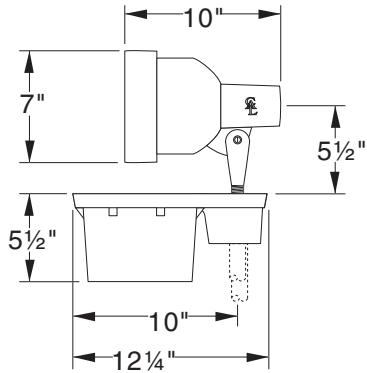

7523 (INC.)

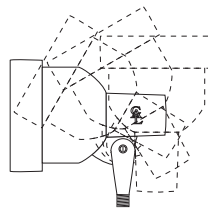
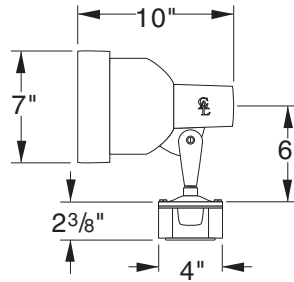

Field Adjustable to 90°

ORDERING INFORMATION

MODEL NO. :
7523

MODEL NO. :

7
5
2
3

PART NUMBERS

PART NUMBERS

- 7525-INC., R-40, 300W
- 7525-QTZ., PAR 38, 250W
- 7525-MV 50, E-17, 50W
- 7525-MV 75, E-17, 75W
- 7525-MV 100, PAR 38, 100W
- 7525-MV 175, R-40, 175W
- 7525-HPS-35, E-17, 35W
- 7525-HPS-50, E-17, 50W
- 7525-HPS-70, E-17, 70W
- 7525-HPS-100, E-17, 100W
- 7525-HPS-150, E-17, 150W
- 7525-MH 35, PAR 30, 35W
- 7525-MH 50, E-17, 50W
- 7525-MH-70, R-40, 70W
- 7525-MH-100, R-40, 100W
- 7525-MH-150, PAR 38, 150W
- 7525-MH 175, R-40, 175W

FINISH

FINISH

- DARK BRONZE. . . . DB
(STANDARD COLOR)
- BLACK.BK
- WHITE.WT
- ALUMINUM.AL

US ARCHITECTURAL. RESERVES THE RIGHT TO MAKE CONTINUED PRODUCT DESIGN AND CONSTRUCTION IMPROVEMENTS WHICH MAY AFFECT THE PRODUCT ILLUSTRATED

