

# ABH / SBH

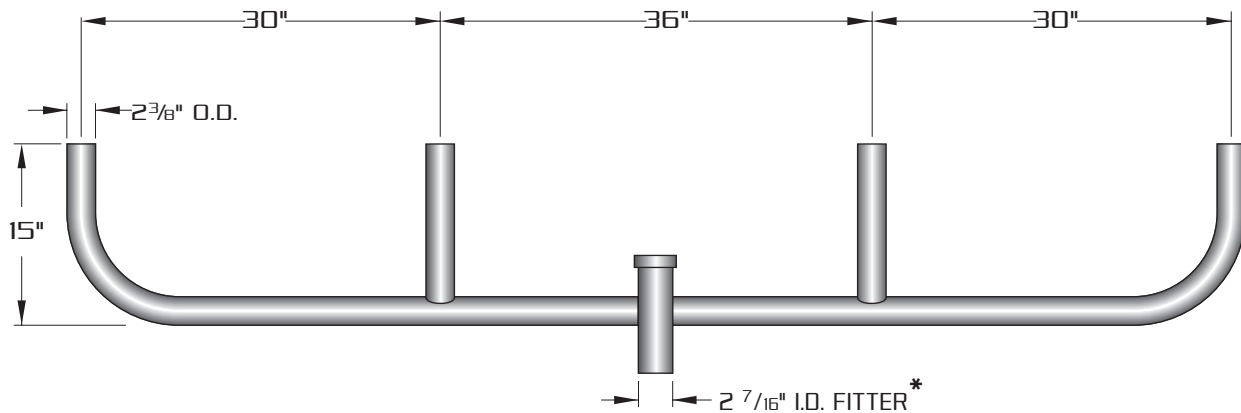

[ALUMINUM=ABH-4-180]  
 [STEEL=SBH-4-180]  
 E.P.A.= 1.85

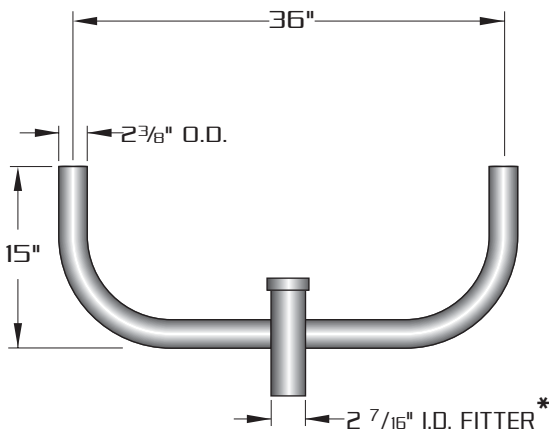

[ALUMINUM=ABH-2-180]  
 [STEEL=SBH-2-180]  
 E.P.A.= 0.81

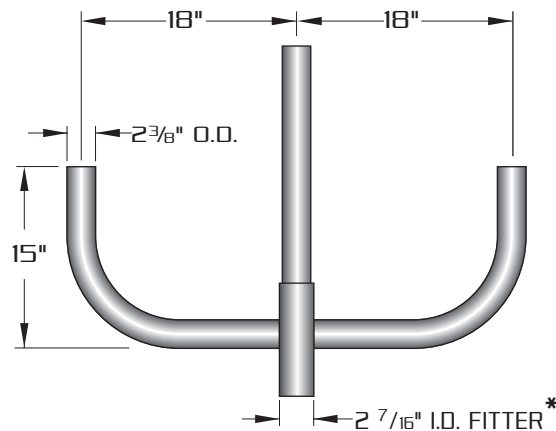

[ALUMINUM=ABH-3-180]  
 [STEEL=SBH-3-180]  
 E.P.A.= 1.04

\*FITTER ACCEPTS  
 2 3/8" O.D. X 4" TENON

ALUMINUM-	ABH-WM	ABH-1	ABH-2-180	ABH-3-180	ABH-3-120	ABH-4-90	ABH-4-120	ABH-4-180
STEEL-	BH-WM	SBH-1	SBH-2-180	SBH-3-180	SBH-3-120	SBH-4-90	SBH-4-120	SBH-4-180

**ALUMINUM:** EXTRUDED FROM 6063 ALLOY ALUMINUM HEAT TREATED TO PRODUCE A T6 TEMPER.

**STEEL:** FABRICATED FROM HIGH GRADE STRUCTURAL QUALITY HOT ROLLED CARBON STEEL.



660 WEST AVENUE O, PALMDALE, CA. 93551  
 (661) 233-2000  
 FAX NO. (661) 233-2001  
 www.usaltg.com