

ASP / SSP

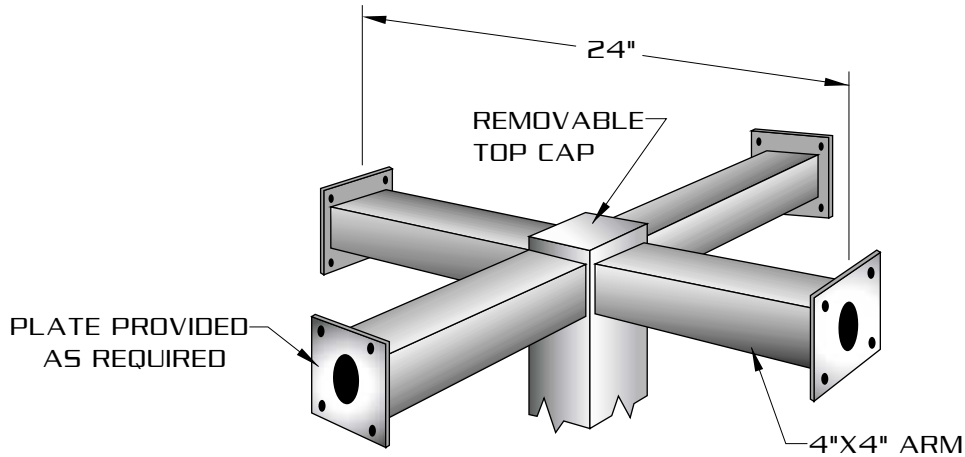

[ALUMINUM=**ASP-4-90**]
 [STEEL=**SSP-4-90**]
 E.P.A.= 0.80

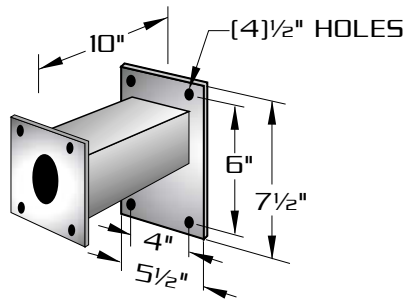

[ALUMINUM=**ASP-WM**]
 [STEEL=**SSP-WM**]

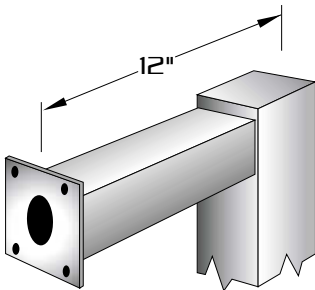

[ALUMINUM=**ASP-1**]
 [STEEL=**SSP-1**]
 E.P.A.= 0.40

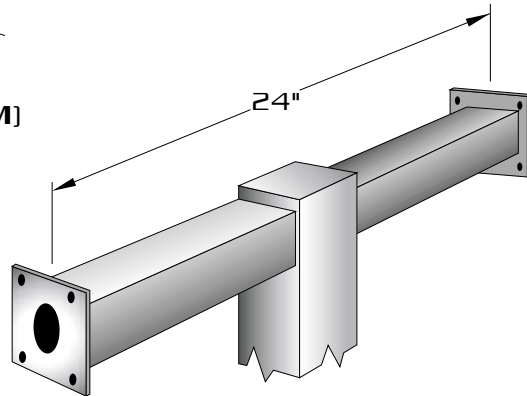

[ALUMINUM=**ASP-2-180**]
 [STEEL=**SSP-2-180**]
 E.P.A.= 0.80



ALUMINUM-	ASP-WM	ASP-1	ASP-2-180	ASP-3-90	ASP-3-180	ASP-4-90	ASPH-4	ASP-5-90
STEEL-	SSP-WM	SSP-1	SSP-2-180	SSP-3-90	SSP-3-180	SSP-4-90	SSPH-4	SSP-5-90

ALUMINUM: EXTRUDED FROM 6063 ALLOY ALUMINUM. HEAT TREATED TO PRODUCE A T6 TEMPER.

STEEL: FABRICATED FROM HIGH GRADE STRUCTURAL QUALITY HOT ROLLED CARBON STEEL.



660 WEST AVENUE O, PALMDALE, CA. 93551
 (661) 233-2000
 FAX NO. (661) 233-2001
www.usaltg.com