

C A M B E R™



PATENTS PENDING

U.S. ARCHITECTURAL
LIGHTING

DAY

CAMBER™

Camber is designed to be seen both day and night. Its daytime form is an eclectic blend of curvilinear and rectilinear lines accentuated by structurally expressive components. As such, Camber becomes an accent element for a broad range of contemporary architectural schemes. Camber is strongly three dimensional, casting interesting wall shadows and creating soft gradations on its own components. Camber will enhance any facade.



NIGHT

CAMBER™

Camber provides a unique array of functional and aesthetic illumination. Its primary light distribution is up and down, with the down light providing building perimeter and entrance illumination. The up light is for architectural features such as overhangs and projections. However, if upward light is not needed, Camber is available with fixed or adjustable indirect reflectors to redirect light downward. Camber also lights its surrounding wall, and its own surfaces, all with a fully shielded lamp to eliminate glare.



SELECTION GUIDE

CBR1

CBR2

FORM

Camber is an eclectic design consisting of curvilinear, rectilinear and structural components. It has a high degree of visual interest resulting from its functional expressiveness. Five Camber models are available, all building from the basic CBR1. As components are added in the CBR2,3,4 and 5, its visual dynamics increase, yet its function is always apparent. Camber is meant to be seen, and should be considered an accent element to the building, complementing the architecture with strong three dimensional forms in a contemporary design.

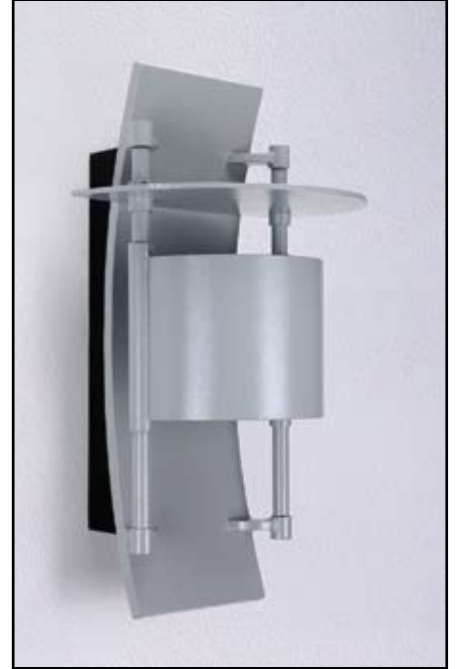

FUNCTION

Camber is a functional luminaire with each model offering unique lighting solutions. All Camber models illuminate their own components with soft glare free light, therefore rendering Camber a visible nighttime accent to the building. The functional aspects of Camber's illumination are down lighting for perimeters and entrances, up lighting for overhangs and projections, and wall illumination for visual accent. If color is desired, the CBR4 offers filters for a splash of upward color.

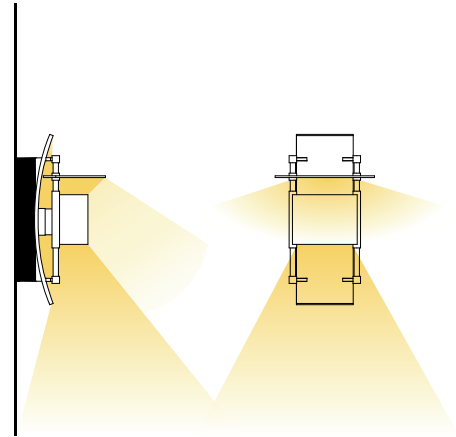
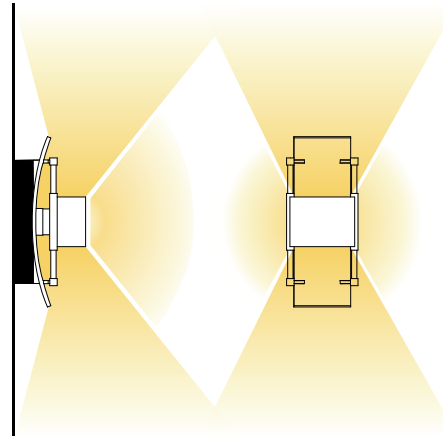

SCALE

Since Camber is designed to be an aesthetic and functional accent to the architecture, it has been sized to balance performance objectives with pedestrian scale. As such, its ideal mounting heights are 8' to 12'. This also applies to interior spaces such as atriums, entrance halls and terminal buildings.

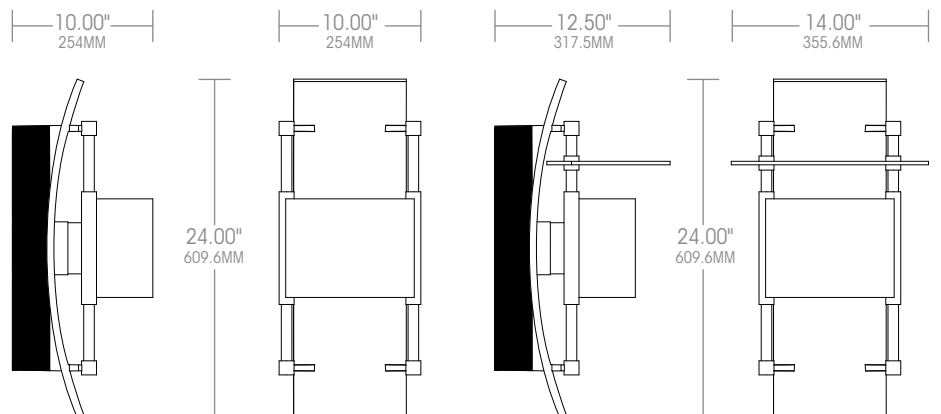

CBR3



CBR4



CBR5

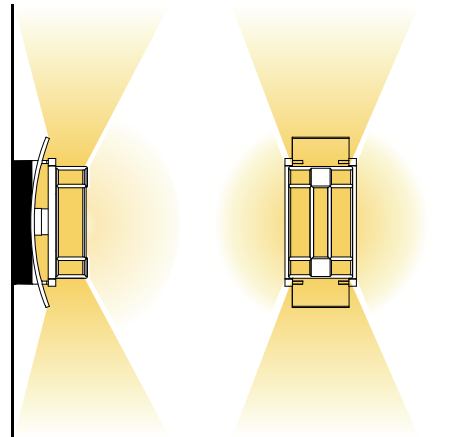
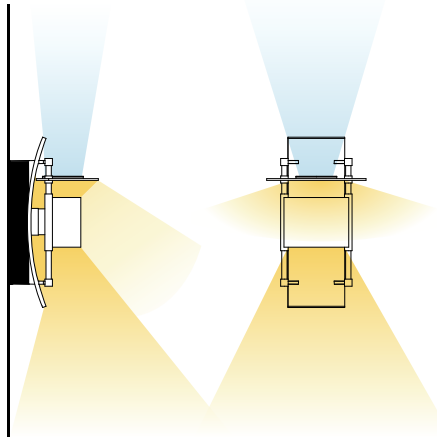
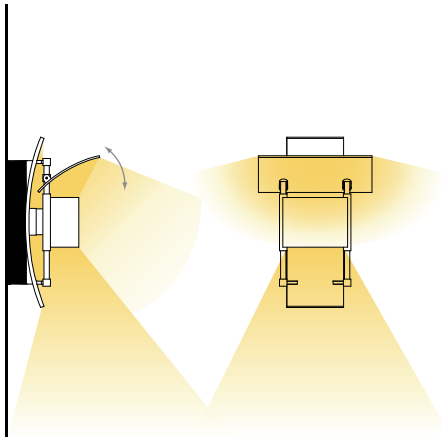

MAX. 13.5"
342.9MM

16.00"
406.4MM

12.50"
317.5MM

14.00"
355.6MM

10.50"
266.7MM

10.00"
254MM

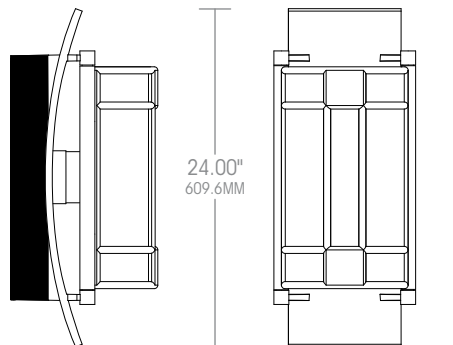
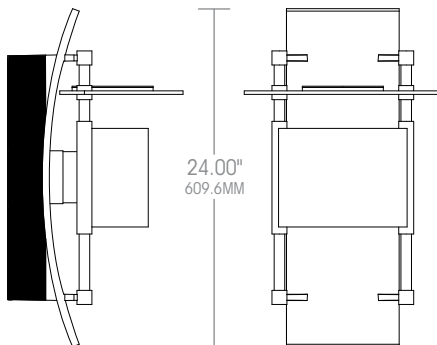
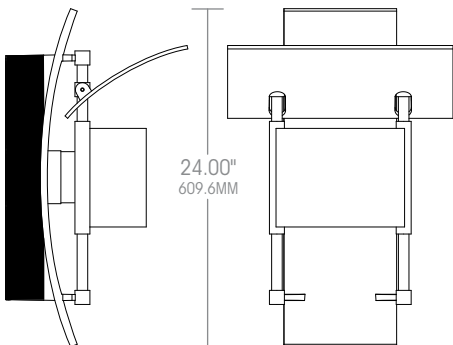

EXTERIOR / INTERIOR APPLICATIONS

While Camber is primarily designed for exterior applications, its attributes are ideal for many interior spaces such as entrance halls, atriums, museums, terminals and interior shopping malls. These high ceiling spaces are ideal for Camber's ability to provide accent lighting on walls, ceilings, architectural features and floors.



MECHANICAL / OPTICAL FEATURES

INSTALLATION

Camber engineering places strong emphasis on ease of installation and maintenance. The Ballast Housing is mounted to the wall independent of the Fixture. Four mounting holes are provided to secure the Ballast Housing to the wall as code requires for the wall type. (Mounting hardware by others). Caulking channels are also provided to seal the Ballast Housing/Wall interface. The Fixture Module can be mounted to the Ballast Housing at any time during construction. To free both hands for wiring, the Fixture Module hangs on slip hinges.



RELAMP

Access to the glass lamp enclosure is accomplished by swinging open the Glare Shield. The fully gasketed lamp enclosure is unscrewed allowing the lamp to be replaced. At the same time, cleaning of the fixture exterior can readily be accomplished.



OPTICAL CONTROL

Camber's Glare Shield has been engineered to allow vertical adjustment. The factory preset is the centered position which provides approximately 45 degrees of lamp cutoff for both up and down light throw. If the Glare Shield is moved downward, the down light narrows while the up light broadens. The opposite happens when the Glare Shield is moved upward.

Up light is not always desired unless there is something to illuminate. The fixed and adjustable indirect reflectors of the CBR2 and CBR3 will capture the up light and bounce it downward, adding to the ground plane illumination and providing additional fixture glow.

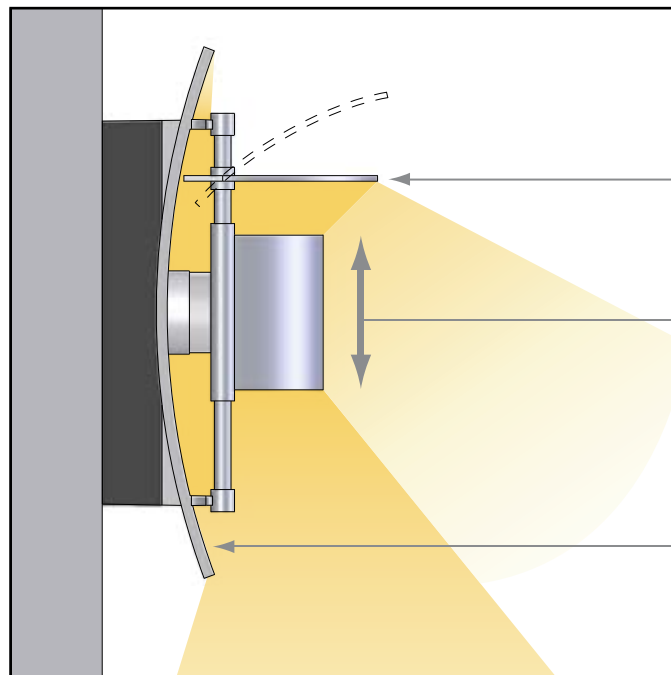

Indirect reflectors are available to redirect upward light downward. The CBR2 is flat and fixed while the CBR3 is a subtle arc and adjustable.

The main Glare Shield has vertical adjustment in five positions which controls up and down light spread and cutoff.

The curved plane of the fixture always reflects light outward creating a soft glow to provide nighttime fixture presence.

SPECIFICATIONS

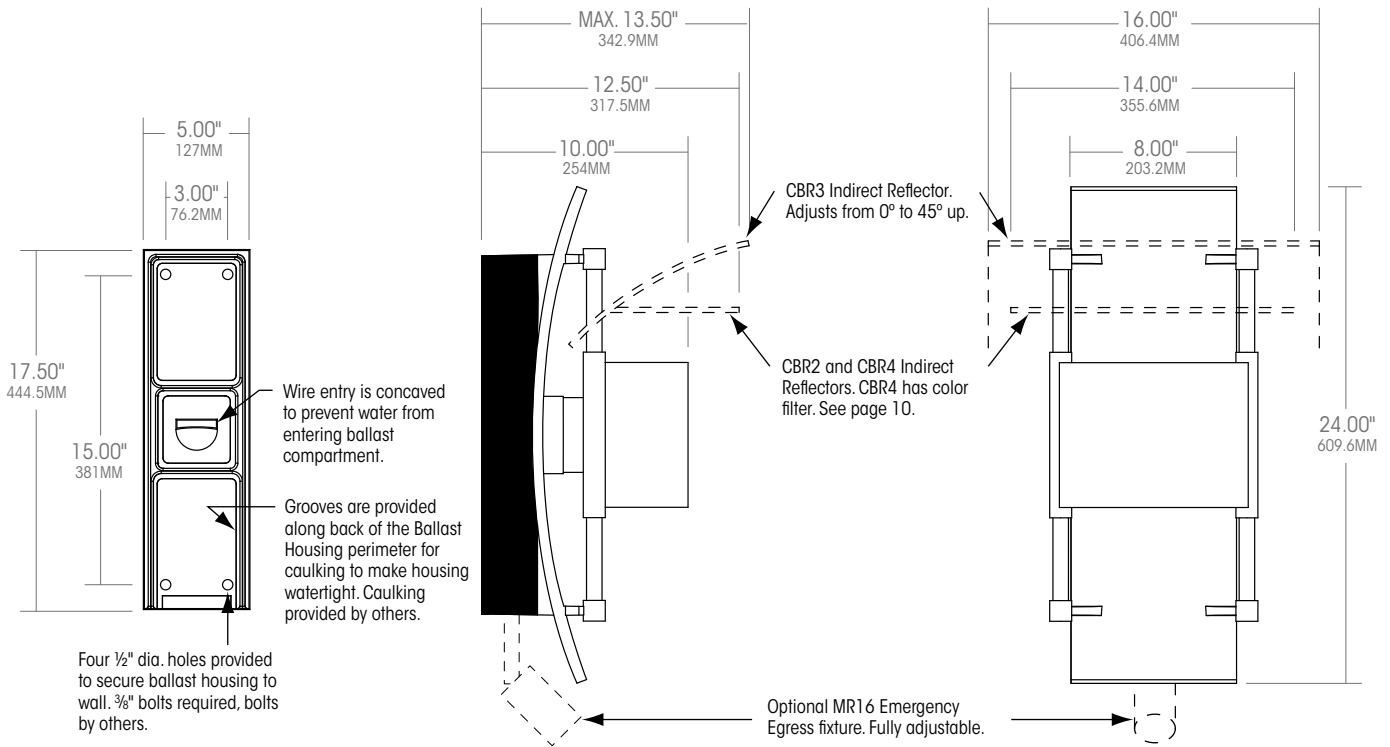

BALLAST HOUSING (all models) Durable corrosion resistant, low copper cast aluminum alloy #A356 (<0.2% Cu) having four (4) 1/2" holes for mounting (3/8" bolts by others). A recessed channel allows for caulking to be applied and secured between the Ballast Housing and mounting surface. Ballast Housing mounts separate from Fixture Body and has integral cast hinges to accept stainless-steel pins for mounting Fixture Body to Ballast Housing. Housing is always black.

FIXTURE (all models) Durable corrosion resistant, low copper cast aluminum alloy #A356 (<0.2% Cu) with inset to index Body to Ballast Housing. Strut support arms are cast as integral components of the Fixture Body. Body mounts to Ballast Housing after Ballast Housing installation via cast hinges designed to accept stainless-steel hinge pins. An integral socket cup has provision for threading and gasketing the lamp enclosure. A stainless steel recessed captive socket-head screw secures the Fixture Body to the Ballast Housing.

STRUTS (Shield Support Arms) Struts are extruded aluminum .84" diameter. Struts are parallel and indexed to allow Glare Shield to be secured in one of five (5) vertical positions. One Strut has stainless steel recessed captive socket-head screws top and bottom to allow Glare Shield, Indirect Reflectors, or Half Cylinder to hinge away for relamping.

LAMP ENCLOSURE One piece molded glass threads into cast aluminum socket cup. Socket cup is gasketed to prevent moisture or other contaminants from entering lamp compartment.

SHIELDS AND REFLECTORS

CBR1 (Glare Shield) Corrosion resistant aluminum construction. Shield has tool-less hardware for indexing in one of five (5) positions (1" increments) along vertical Struts.

CBR2 (Flat Indirect Reflector) Constructed of corrosion resistant low copper cast aluminum alloy #A356 (<0.2% Cu). Indirect reflector is flat and has stainless steel socket-head screws to secure its vertical position along the Struts.

CBR3 (Curved Indirect Reflector) Constructed of corrosion resistant low copper cast aluminum alloy #A356 (<0.2% Cu). Indirect reflector is curved and has stainless steel socket-head screws to secure its vertical position along the Struts. Curved indirect reflector is adjustable for tilt from 0° (horizontal) to 45° up.

CBR4 (Flat Indirect Reflector w/ Color Filter) Constructed of corrosion resistant low copper cast aluminum alloy #A356 (<0.2% Cu). Indirect reflector is flat and has stainless steel socket-head screws to secure its vertical position along the Struts. Indirect reflector has provision for mounting color filter.

CBR5 (Full Cage Diffuser) Cage constructed of corrosion resistant low copper cast aluminum alloy #A356 (<0.2% Cu). Diffuser is mounted under cage and is opal white UV stabilized acrylic with minimum wall thickness of .125".

LAMP / ELECTRICAL GUIDE

LAMP WATTAGE	LAMP TYPE	SYSTEM WATTS	BULB TYPE	INITIAL LUMENS	LIFE (HOURS)	ANSI CODE	STARTING TEMP.	CIRCUIT TYPE	VOLTAGE	OPT. AMPS	OPEN CIRCUIT AMPS	STARTING AMPS	MIN. FUSE AMPS
PULSE START METAL HALIDE													
50	PSMH	56	Clear, ED17, Med Base	4,100	10,000	M110	-20°F	Electronic	120	-	-	0.47	2
									277	-	-	0.20	2
70	PSMH	80	Clear, ED17, Med Base Clear, T6, G12 Base	5,300	16,000	M98 M143	-20°F	Electronic	120	-	-	0.67	4
									208	-	-	0.45	3
									240	-	-	0.38	2
									277	-	-	0.30	2
100	PSMH	129	Clear, ED17, Med Base	8,500	15,000	M90 M140	-20°F	Electronic	120	-	-	0.92	6
									208	-	-	0.70	4
									240	-	-	0.60	3
									277	-	-	0.40	3

HIGH PRESSURE SODIUM

50	HPS		Clear, ED17, Med Base	4,000	24,000	S68	-40°F	HPF	120	0.55	0.90	1.00	3
70	HPS		Clear, ED17, Med Base	6,300	24,000	S62	-40°F	HPF	120	0.75	1.30	1.30	3
100	HPS		Clear, ED17, Med Base	9,500	24,000	S54	-40°F	HPF	120	1.05	1.80	1.80	5

COMPACT FLUORESCENT

42	PL	46	Coated, GX24q-4 Base	3,200									
----	----	----	----------------------	-------	--	--	--	--	--	--	--	--	--

NOTE: 42W, 32W and 26W lamps use the same ballast.

NOTES:

- ① U.S. Architectural Lighting's Lamp and Electrical Guide is for reference only. ALWAYS consult lamp manufacturer's data for exact technical specifications.
- ② All Initial Lumen values shown are approximate in the vertical position and may vary from one manufacturer to another.
- ③ All electrical data for Emergence Egress circuit is dependent upon power source. (see note #4)
- ④ Emergency Egress circuit is discreet for 12volt supply from generator, inverter, or battery back-up.

WARNING: All fixtures must be installed in accordance with local codes or the National Electrical Code. Failure to do so may result in serious personal injury.

ELECTRICAL COMPONENTS All electrical components are UL recognized. High power factor ballasts are rigidly mounted inside the Fixture Body and are factory prewired with a quick-disconnect plug for mating to the socket. HPS core and coil ballast, reactor - high power factor with starting temperatures of -40°F. MH electronic HID ballasts are high power factor, low frequency, -20°F starting. Fluorescent ballasts are electronic, high power factor, 0°F starting. HID socket is 4KV pulse rated medium base. Optional G-12 base socket is available for 70PSMH T6 lamp mode. Fluorescent socket is universal for 26W, 32W, or 42W PL lamps.

GASKETS Between Ballast Housing and Fixture Body – One-piece continuous EPDM gasket with seam located on bottom edge of housing. Between Lens and Socket Cup – One-piece molded silicone gasket.

OPTIONAL EMERGENCY EGRESS Trilux Model TLX-SF MR16 20W to 50W fully adjustable fixture rated for outdoor application. Discrete wiring circuit for connection to an emergency generator, inverter, or to battery back-up (by others). (Refer to www.usaltg.com for detailed fixture specification)

FINISH Electrostatically applied TGIC Polyester Powder Coat on substrate prepared with 20 PSI pressure power wash at 140° F.; four step iron phosphate pretreatment for protection and paint adhesion: baked at 400°F for maximum hardness and durability.



IP65

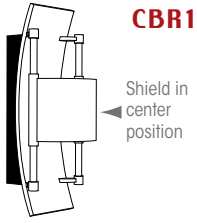

CBR1

Shield in center position

100W PMH

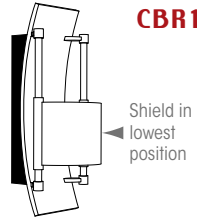
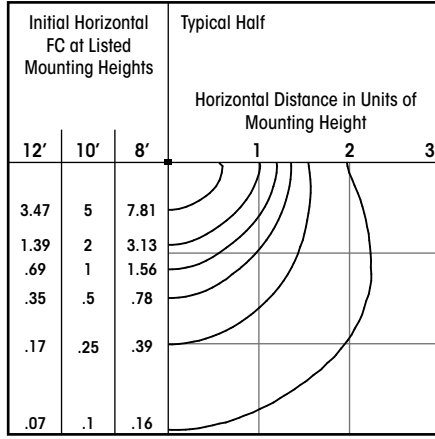

CBR1

Shield in lowest position

100W PMH

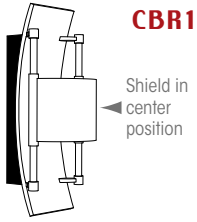
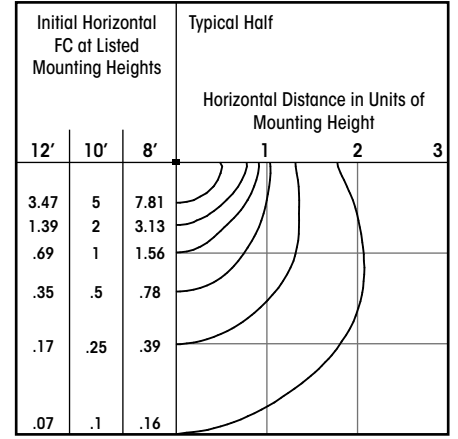

CBR1

Shield in center position

42 PL

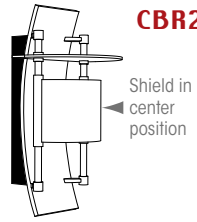
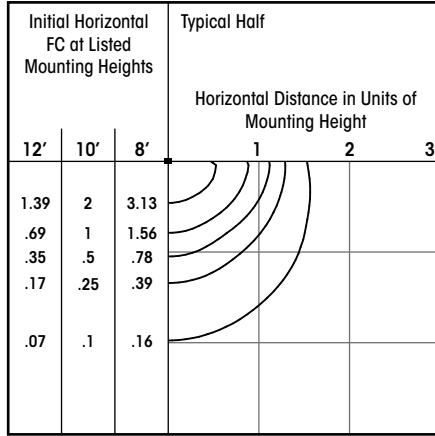

CBR2

Shield in center position

100W PMH

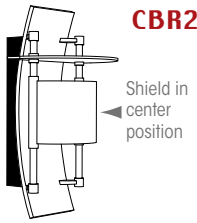
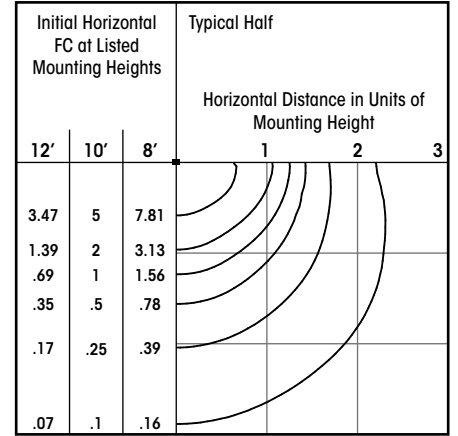

CBR2

Shield in center position

42 PL

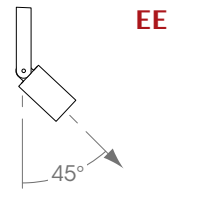
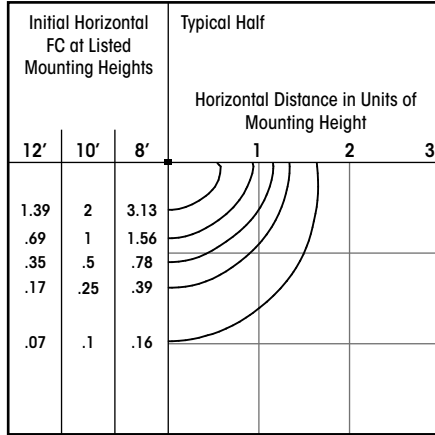

EE

45°

50W MR16 FLOOD

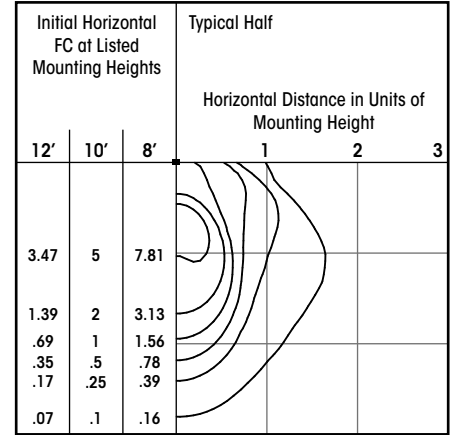

CONVERSION FACTORS FOR OTHER LAMPS

Multiply FC values by these factors

	FROM	70PMH	100PMH	26PL	32PL	42PL	50HPS	70HPS	100HPS	
TO	50PMH	0	0.77	0.48	2.28	1.71	1.28	1.03	0.65	0.43
	70PMH	1.29	0	0.62	2.94	2.21	1.66	1.33	0.84	0.56
	100PMH	2.07	1.60	0	4.72	3.54	2.66	2.13	1.35	0.89
	26PL	0.44	0.34	0.21	0	0.75	0.56	0.45	0.29	0.19
	32PL	0.59	0.45	0.28	1.33	0	0.75	0.60	0.38	0.25
	42PL	0.78	0.6	0.38	1.78	1.33	0	0.80	0.51	0.34
	50HPS	0.98	0.75	0.47	2.22	1.67	1.25	0	0.63	0.42
	70HPS	1.54	1.19	0.74	3.50	2.63	1.97	1.58	0	0.66
	100HPS	2.32	1.79	1.12	5.28	3.96	2.97	2.38	1.51	0

ORDERING INFORMATION

Ordering Example

CBR4 / 70PSMH120 / RAL-9005 / CF15 / EE

Fixture Electrical Mode Finish Option Option

1 2 3 4 5

1. FIXTURE

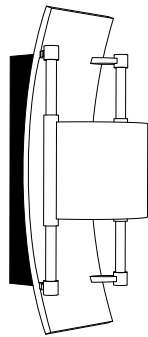

CBR1

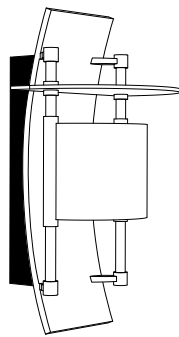

CBR2

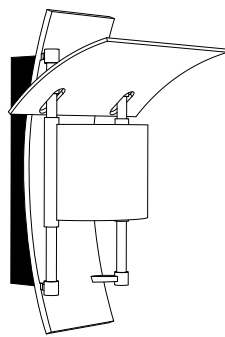

CBR3

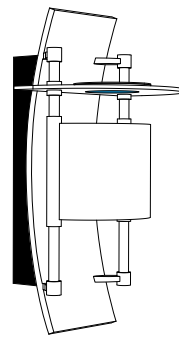

CBR4

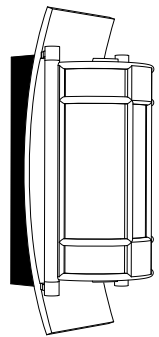

CBR5

2. ELECTRICAL MODE

EXAMPLE

LAMP WATTS	LAMP TYPE	LINE VOLTS
100	PSMH	277

PULSE START METAL HALIDE

50PSMH120	70PSMH120	70PSMH120T6	100PSMH120
50PSMH277	70PSMH208	70PSMH208T6	100PSMH208
	70PSMH240	70PSMH240T6	100PSMH240
	70PSMH277	70PSMH277T6	100PSMH277
	70PSMH347		100PSMH347

HIGH PRESSURE SODIUM

50HPS120	70HPS120	100HPS120
----------	----------	-----------

COMPACT FLUORESCENT

42PL120
42PL208
42PL240
42PL277

NOTE: 42W, 32W and 26W lamps use the same ballast.

PRODUCT IS AVAILABLE IN LED - CONSULT FACTORY.



3. FINISH

Electrostatically applied TGK powder coating features a multi-step finishing process to produce a durable weather resistant finish.

COLOR	TEXTURED	SMOOTH
BLACK	RAL-9005-T	RAL-9005
WHITE	RAL-9003-T	RAL-9003
GREY	RAL-7004-T	RAL-7004
DARK BRONZE	RAL-8019-T	RAL-8019
GREEN	RAL-6005-T	RAL-6005

NOTE: Other colors available. (Refer to www.usaltg.com/RAL-Colors.html)

4. COLOR FILTERS FOR CBR4

Color Filters are for accent color on building overhangs, reliefs and projections.

	CLEAR	CFC
	DEEP STRAW 15	CF15
	MEDIUM RED 27	CF27
	BRILLIANT BLUE 69	CF69
	PRIMARY GREEN 91	CF91

NOTE: Other colors available.

5. OPTIONAL EMERGENCY EGRESS

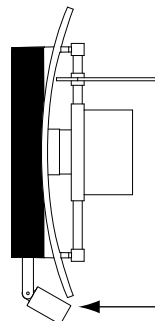

CAT. NO. EE
Trilux Model TLX-SF
20W to 50W MR16 fixture
for discrete wiring back
to emergency generator,
inverter or battery backup
by others.

CAMBER™

Product Design by Wayne Compton



U.S. ARCHITECTURAL
LIGHTING

U.S. POLE COMPANY
660 West Avenue O
Palmdale, California 93551
Toll Free (800) 877-6537
www.usaltg.com