

DURABLE CORROSION RESISTANT, CAST ALUMINUM CONSTRUCTION.

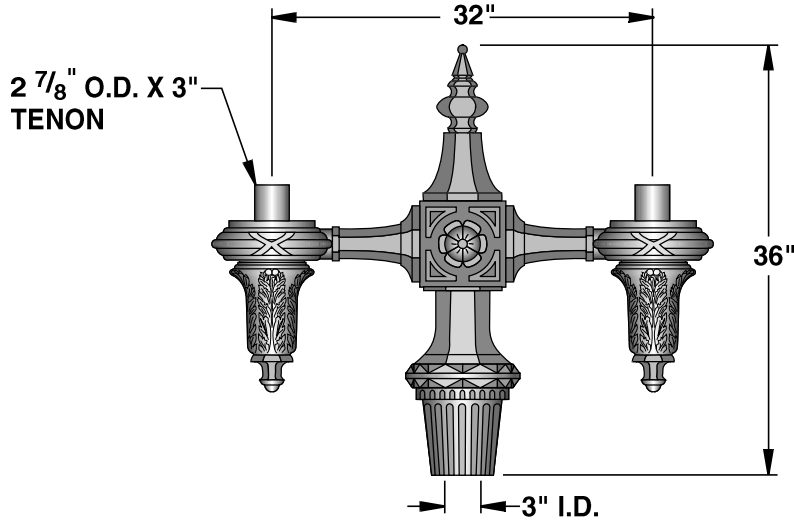

XAP-2-180

SCALE: 3/4"=1'-0"

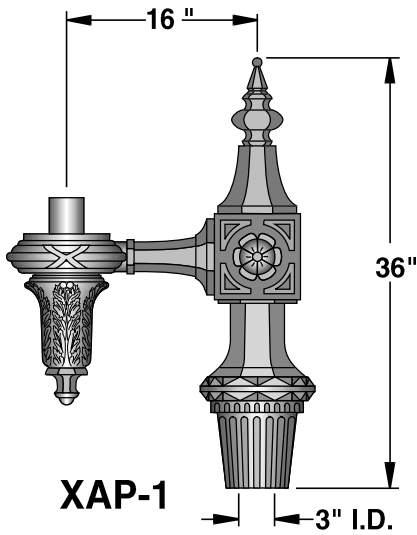

XAP-1

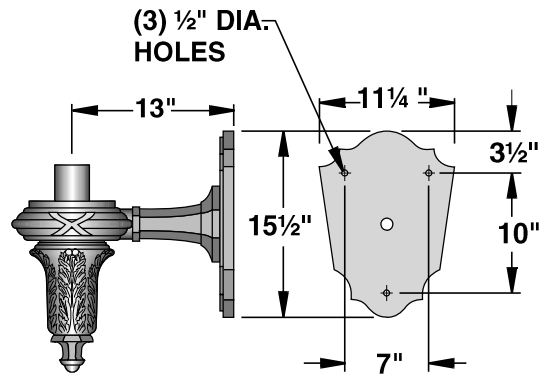

XAP-WM

