

# PENDANT MOUNTED ARM

## XCNA MINI

PROJECT NAME: \_\_\_\_\_

PROJECT TYPE: \_\_\_\_\_

### FEATURES

#### Arm

Durable corrosion resistant, cast aluminum construction.

#### Finish

Super TGIC polyester powder coating is applied onto a metal substrate this has been pretreated with a four-stage process for maximum adhesion and color retention. The top coat is baked at 400° F for maximum hardness and exterior durability.



**XCNAM**

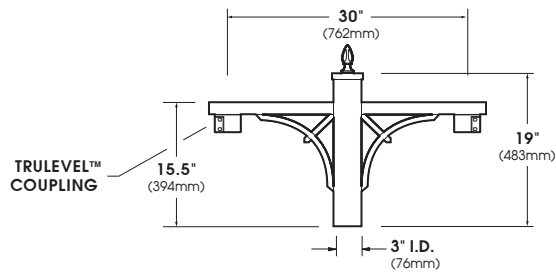

**XCNAM-2-180**  
EPA = 1.00

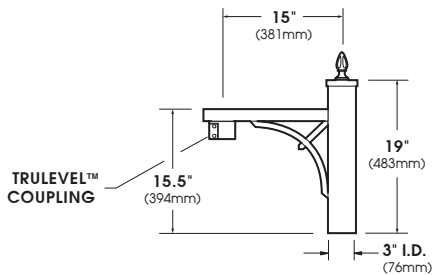

**XCNAM-1**  
EPA = 0.68

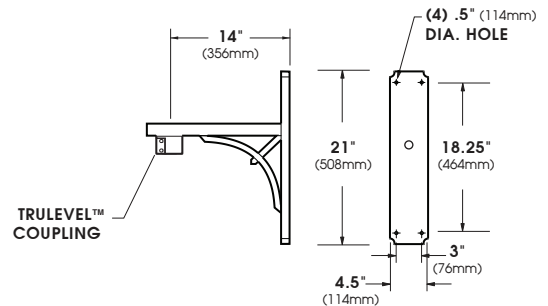

**XCNAM-WM**

SCALE: 1/2"=1'

# XCNAM

## SPECIFICATIONS

### Trulevel System® Assembly

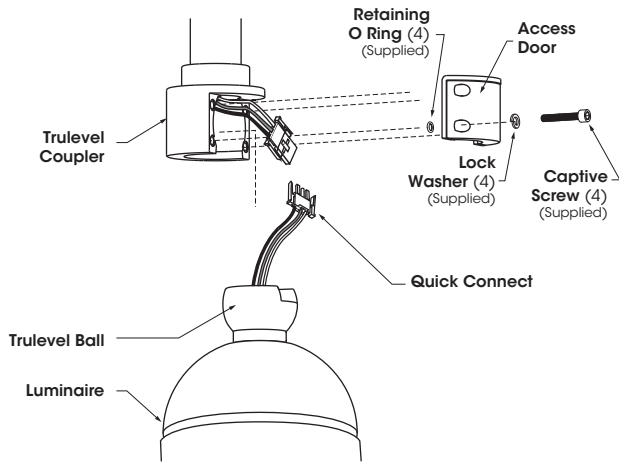

1. Loosen (4) Captive Screws and remove Access Door from Trulevel Coupler, pull out Quick Connect from Trulevel Coupler and Trulevel Ball.

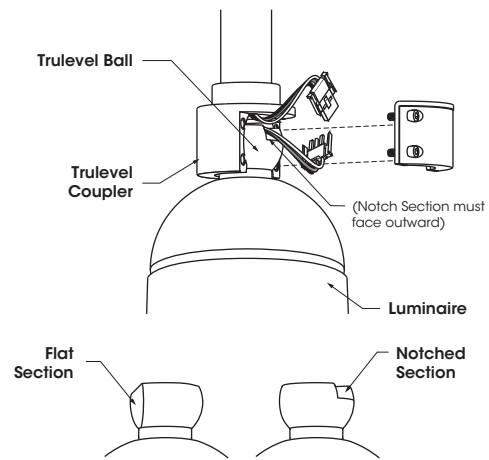

2. Place Trulevel Ball inside of Trulevel Coupler as illustrated.

A - Notched Section of Trulevel Ball must face outward as illustrated.

B - Flat Section of Trulevel Ball must face inward.

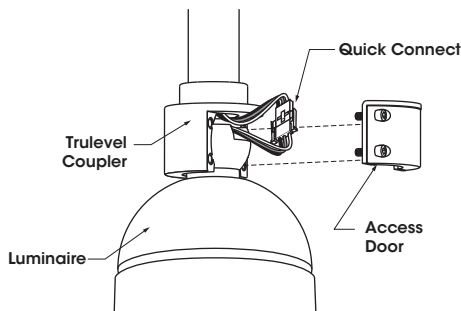

3. Connect Quick Connect components, push components inside of Trulevel Coupler cavity, replace Access Door and loosely secure, do not tighten.

Fixture will suspend without Access Door during installation.

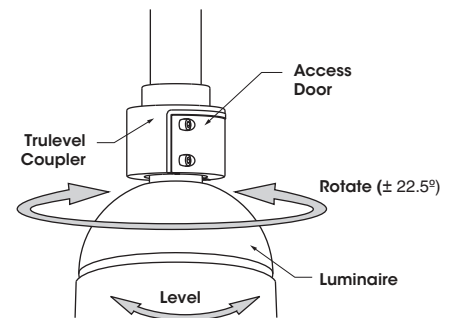

4. Rotate (left to right  $\pm 22.5^\circ$ ) and level Luminaire to desired position. Tighten Access Door.

(Tighten each bolt to recommended torque: **10 ft-lb, foot-pound**)

Trulevel Pendant Mount is intended to allow for fixture leveling, but is not intended to be "free-swinging" upon proper installation.

## ORDERING INFORMATION

Spec/Order Example: XCNAM-5-90/RAL-7004-T

Configuration								
	<input type="checkbox"/> XCNAM-WM	<input type="checkbox"/> XCNAM-1	<input type="checkbox"/> XCNAM-2-180	<input type="checkbox"/> XCNAM-3-180	<input type="checkbox"/> XCNAM-3-120	<input type="checkbox"/> XCNAM-4-120	<input type="checkbox"/> XCNAM-4-90	<input type="checkbox"/> XCNAM-5-90
Finish*	<input type="checkbox"/> Black RAL-9005-T	<input type="checkbox"/> White RAL-9003-T	<input type="checkbox"/> Grey RAL-7004-T	<input type="checkbox"/> Dark Bronze RAL-8019-T	<input type="checkbox"/> Green RAL-6005-T	Premium Finishes		
						<input type="checkbox"/> Rust	<input type="checkbox"/> Patina Copper PC	

\*Standard texture finish. For smooth finish replace suffix "T" with suffix "S" (Example: RAL-9005-S)  
Consult factory for custom colors