

POLE MOUNTING BRACKET

UNIVERSAL POLE ADAPTOR

FEATURES

Housing w/ Pole Bracket

Two heavy wall, interlocking aluminum extrusions (6063-T5 alloy). Pole Bracket is supplied with a Gasket for the Bracket-to-Pole attachment and is curved on one side and flat on the other to accommodate round (4"-6" dia.) and square Poles. Pole Bracket has two holes on top and two slotted openings on the bottom to accommodate Pole drillings for mounting bolts and Wireway. Top and bottom Access Doors are gasketed and bolted (1/4" stainless steel) to the Housing.

Finish

Electrostatically applied TGIC Polyester Powder Coat on substrate prepared with 20 PSI power wash at 140°F. Four step media blast and iron phosphate pretreatment for protection and paint adhesion. 400°F bake for maximum hardness and durability.



UPA

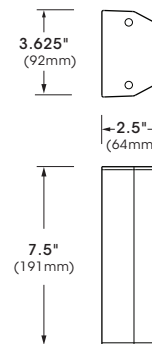

1.5" = 1'

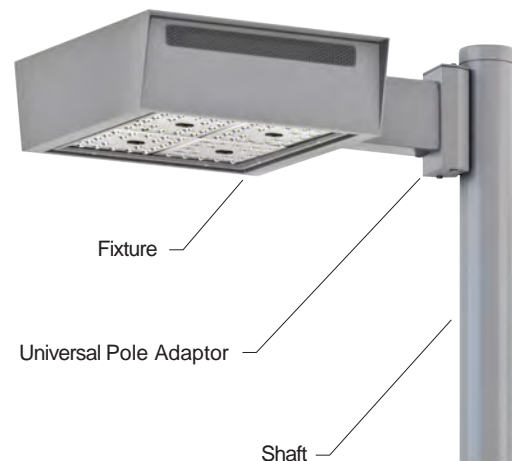

2024039

INSTALLATION INSTRUCTIONS

WARNING - Before starting installation, disconnect power by turning off the circuit breaker or removing fuse at fuse box. Turning the power off using light switch is not sufficient to prevent electrical shock.

To replace an existing fixture, disconnect and remove old fixture.

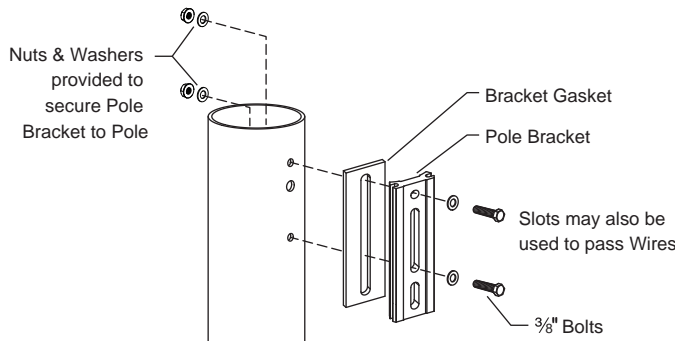

POLE BRACKET

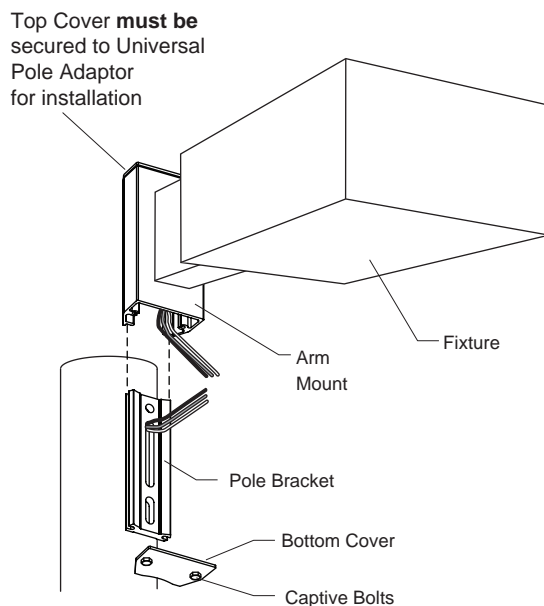
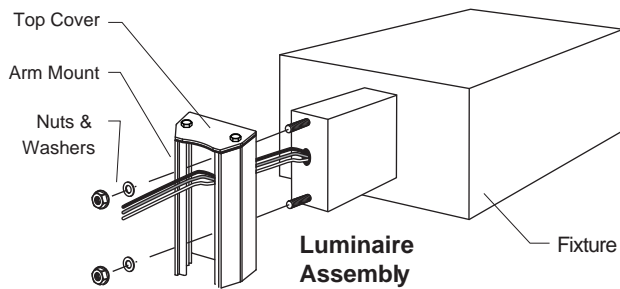
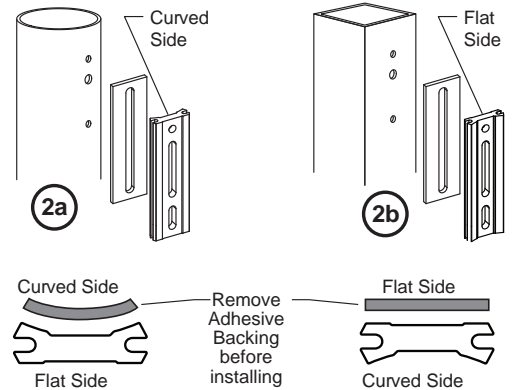

1. Remove Bottom Cover (Cover with no Gasket) place Gasket on Bracket as indicated on **2a** OR **2b**.
- 2a. Install Bracket Gasket on curved side for round Pole.
- 2b. Install Bracket Gasket on flat side for square pole.
3. Secure Pole Bracket to Pole using Bolts, Nuts and Washers (provided), push Service Wires thru and into Pole Bracket. Insure that Bracket is leveled before final tightening to obtain optimal Luminaire positioning.
4. Insert Bolts from Luminaire thru Arm Mount, pull Wires thru and into Arm Mount. Secure Luminaire to Arm Mount with two Nuts & Washers (provided).
5. Slide Arm Mount/Fixture Assembly over Pole Bracket, Top Cover **MUST BE** securely attached to Arm Mount.
6. Make Electrical Connections connect Wires from Fixture to Wires from Supply Circuit. Using U.L. listed Wire Connectors, connect Grounding Wire (green or bare copper) to green Wire, white Wire to white Wire and black Wire to black Wire.
7. Push Wires inside Arm Mount Cavity to allow Bottom Cover to sit flush.
8. Close Arm Mount Cavity with Bottom Cover and two Bolts.