

# PENDANT MOUNTED ARM

# XAZ-PM

PROJECT NAME: \_\_\_\_\_

PROJECT TYPE: \_\_\_\_\_

## FEATURES

### Arm

Durable corrosion resistant, cast aluminum construction.

### Finish

Electrostatically applied TGIC Polyester Powder Coat on substrate prepared with 20 PSI power wash at 140°F. Four step media blast and iron phosphate pretreatment for protection and paint adhesion. 400°F bake for maximum hardness and durability.



**XAZ-PM-UP**

Patent pending

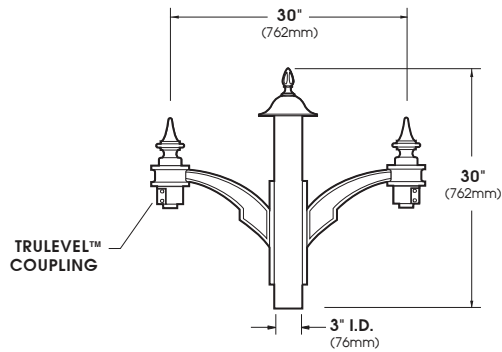

**XAZ-PM-UP-2-180**  
EPA = 1.29

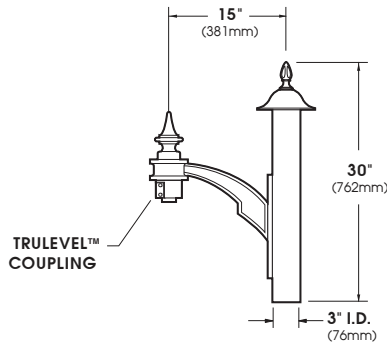

**XAZ-PM-UP-1**  
EPA = 0.90

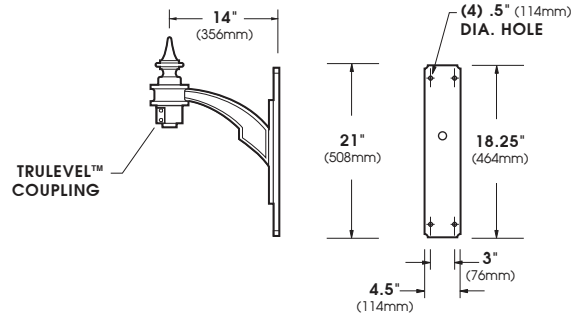

**XAZ-PM-UP-WM**  
EPA = 0.52

SCALE: 1/2"=1'

# XAZ-PM

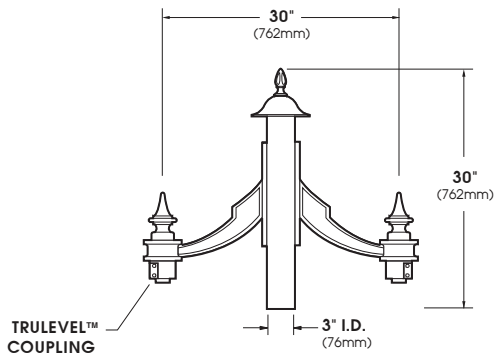

**XAZ-PM-DN-2-180**  
EPA = 1.29



**XAZ-PM-DN**

Patent pending

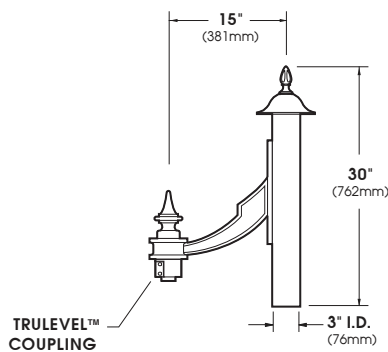



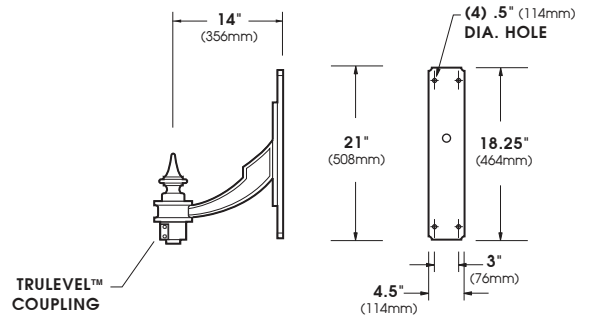







**XAZ-PM-DN-1**  
EPA = 0.90



**XAZ-PM-DN-WM**  
EPA = 0.52

## ORDERING INFORMATION

Spec/Order Example: XAZ-PM-DN-4-90/RAL-6005-T

Positioning	<input type="checkbox"/>  <b>XAZ-PM-UP</b>	<input type="checkbox"/>  <b>XAZ-PM-DN</b>						
Configuration	<input type="checkbox"/>  <b>XAZ-PM-WM</b>	<input type="checkbox"/>  <b>XAZ-PM-1</b>	<input type="checkbox"/>  <b>XAZ-PM-2-180</b>	<input type="checkbox"/>  <b>XAZ-PM-3-180</b>	<input type="checkbox"/>  <b>XAZ-PM-3-120</b>	<input type="checkbox"/>  <b>XAZ-PM-4-120</b>	<input type="checkbox"/>  <b>XAZ-PM-4-90</b>	<input type="checkbox"/>  <b>XAZ-PM-5-90</b>
Finish*	<input type="checkbox"/> Black <b>RAL-9005-T</b>	<input type="checkbox"/> White <b>RAL-9003-T</b>	<input type="checkbox"/> Grey <b>RAL-7004-T</b>	<input type="checkbox"/> Dark Bronze <b>RAL-8019-T</b>	<input type="checkbox"/> Green <b>RAL-6005-T</b>	<p>*Standard texture finish For smooth finish replace suffix "T" with suffix "S" (Example: RAL-9005-S) Consult factory for custom colors</p>		



# XAZ-PM

## SPECIFICATIONS

### Trulevel System® Assembly

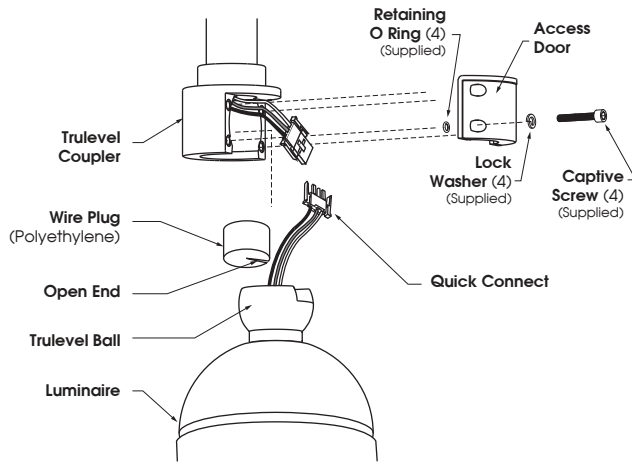

1. Loosen (4) Captive Screws and remove Access Door from Trulevel Coupler, pull out Quick Connect from Trulevel Coupler and Trulevel Ball.

Press open end of Wire Plug around Quick Connect wires.

Slide Wire Plug down the wires and into Trulevel Ball opening, press Neoprene firmly into opening to prevent moisture and other contaminants from entering Luminaire Assembly.

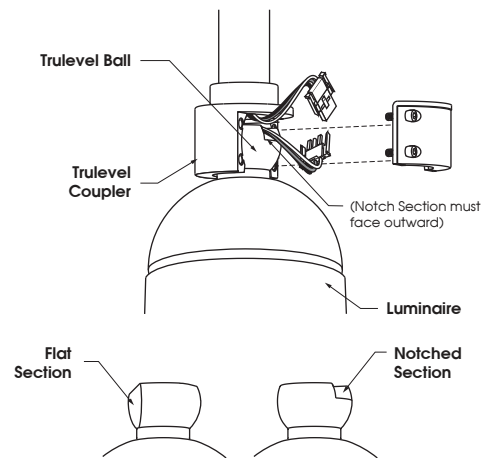

2. Place Trulevel Ball inside of Trulevel Coupler as illustrated.

A - Notched Section of Trulevel Ball must face outward as illustrated.

B - Flat Section of Trulevel Ball must face inward.

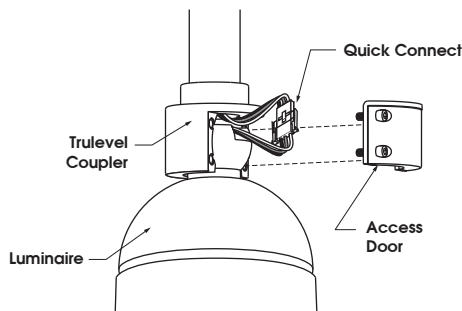

3. Connect Quick Connect components, push components inside of Trulevel Coupler cavity, replace Access Door and loosely secure, do not tighten.

Fixture will suspend without Access Door during installation.

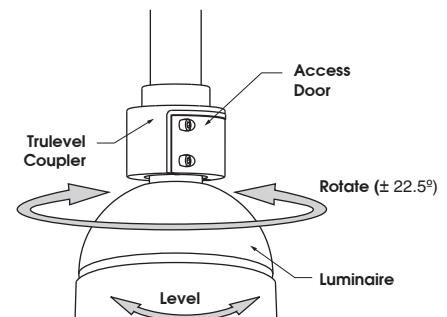

4. Rotate (left to right  $\pm 22.5^\circ$ ) and level Luminaire to desired position. Tighten Access Door.

(Tighten each bolt to recommended torque: **10 ft-lb, foot-pound**)

Trulevel Pendant Mount is intended to allow for fixture leveling, but is not intended to be "free-swinging" upon proper installation.