

TRADITIONAL STYLED BASE

5300 Series

Base

One piece corrosion resistant, durable cast aluminum construction, minimum .210 wall thickness. Base consists of an octagonal, stepped bottom section with Hand Hole and a decorative fluted section consisting of evenly spaced, highly detailed raised vertical flutes. Hand Hole Cover supplied with tamper resistant hardware. Grounding Lug provided inside Base opposite Hand Hole.

Anchorage

A 3/4" cast aluminum anchor ring is welded 1" above bottom of base to accept (4) fully galvanized anchor bolts. Each bolt supplied with two nuts and two washers. Anchorage is fastened through hand hole.

Finish

Electrostatically applied TGIC Polyester Powder Coat on substrate prepared with 20 PSI power wash at 140°F. Four step media blast and iron phosphate pretreatment for protection and paint adhesion. 400°F bake for maximum hardness and durability.

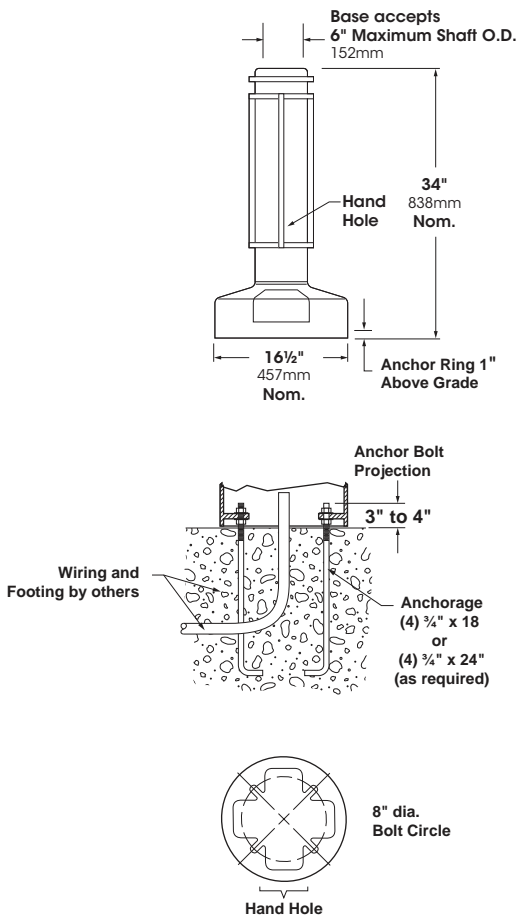
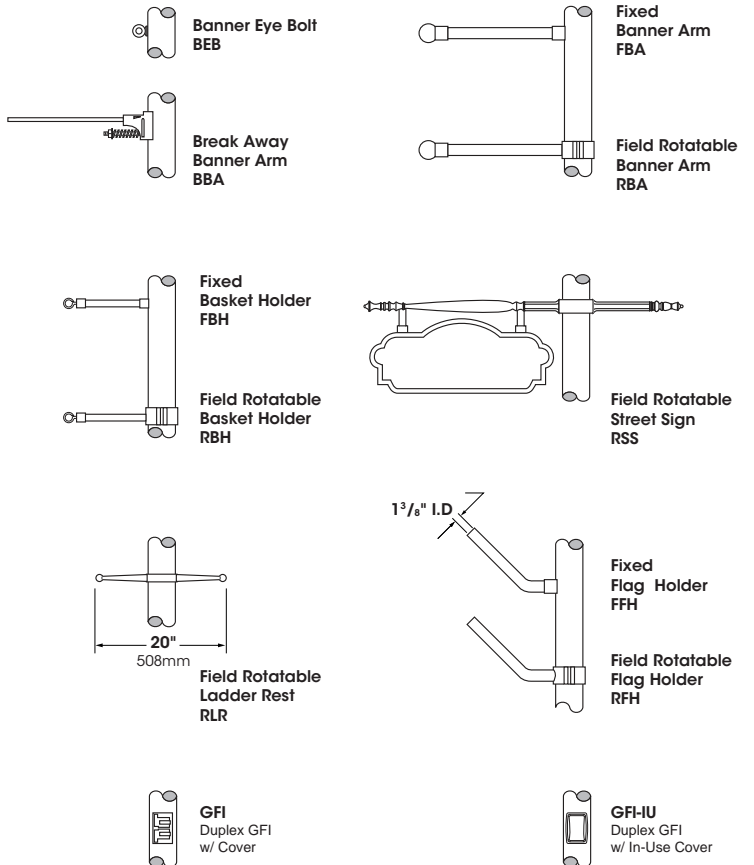
5300
ANCHORAGE DATA

OPTIONS

<https://www.usaltg.com/downloads/pdf/Pole-Arm-Accessories.pdf>

2024057