

# Razar LED Generation

The Ultimate in LED Site Illumination



MADE IN THE  
**USA**

Patents Pending

**U.S. ARCHITECTURAL**  
**LIGHTING**

# Family of Products

## Ultimate Application Flexibility

The era of LED's is upon us. This source technology has impressed itself on the field of lighting in a manner never before seen. Now is the time for a generation of luminaires that leverage the power and flexibility, the precision and longevity LED's bring to the world of illumination.

Now is the time for the Razar LED Generation.

The Razar LED Generation satisfies all the performance illumination requirements in the market today with a cohesive family of side arm pole mounted, wall mounted, post top mounted and mast arm luminaires including bollards. Multiple sizes keep the appearance balanced and in scale regardless of the mounting height and the aesthetic language maintains architectural harmony.

The optical components are consistent throughout all luminaires that make up the Razar LED Generation as are their capabilities - field rotatability and replacement, the range of drive currents, dimming, the list goes on.

The Razar LED Generation - LED illumination as it should be done.



### Heavy Duty Cast Components

The Razar optical housings and arm/electrical compartment components are all constructed of durable corrosion resistant precise low copper aluminum castings with  $\frac{1}{4}$ " minimum wall thickness. Prior to finishing, all castings are sand blasted to create a uniform and clean surface for paint adhesion.

# Razar LED

## Site/Area

Razar LED represents the fullest complement of form and technology in LED illumination. Robust **cast aluminum** housings stand up to all outdoor conditions while creating a form that is both elegant and reflective of its technological core.

Three housing sizes allow for the selection of the most properly scaled luminaire body so that at the selected mounting height the overall assembly looks balanced and harmonious with the architectural context.

Optically Razar LED allows for the ideal selection of LED count, color temperature, and drive current to provide pleasing illumination levels and complementary illumination of the visual terrain. Controlled optics also eliminate uplight (light pollution) and minimize spill light (light trespass) with a **wide variety of distribution patterns** that include **house side shielding** to suit the requirements of the site.

All told it would be difficult to find any luminaire family better suited to fulfill the task of LED illumination other than Razar LED by U.S. Architectural Lighting.



### Site Adaptive Pole Mounting Configurations

The ability to rotate asymmetric optical patterns by 90° increments combines with a wide variety of luminaire mounting configurations to allow complete illumination coverage of any site.

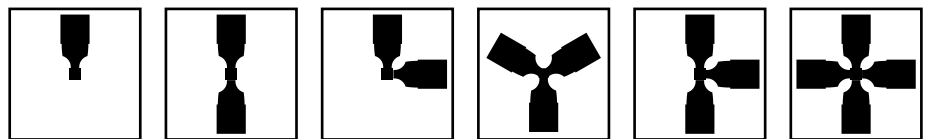

Examples of the flexibility of distribution coverage from twin mount luminaires @ 180°:

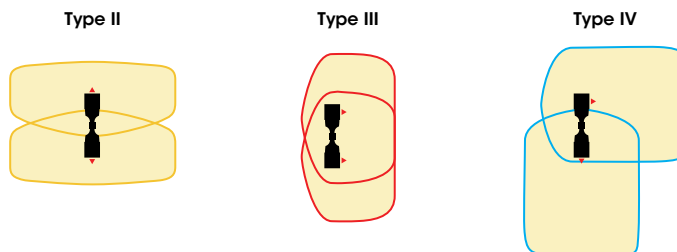

In addition, the individually rotatable panels create the same effect by rotating the panels in a single luminaire independently.

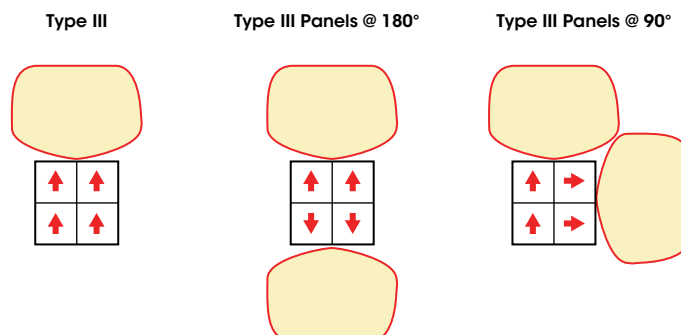

# PLED® Optics

The U.S. Architectural **PLED**® (Panel LED) System utilizes a micro reflector behind each LED in asymmetric distributions to enhance forward throw and reduce backlight. Each LED is optically controlled by a lens that has its distribution type and direction of light throw molded into it.

The LED's and lenses are arrayed on circuit boards that are field rotatable in 90° increments and field replaceable.

Ultra high performance optics developed by U.S. Architectural



Micro-reflector behind LED enhances forward throw and reduces backlight

Distribution type and direction of light throw

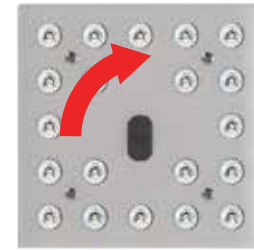
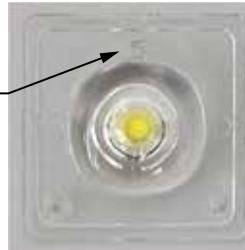

90° field rotatable

## Available Light Distributions

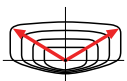

Type II\*

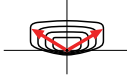

Type II FR\*

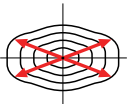

Type II ML

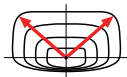

Type III M\*

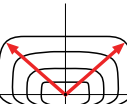

Type III W\*

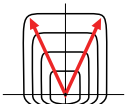

Type IV\*

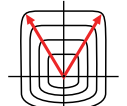

Type IV FT\*

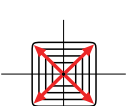

Type V Sq. N

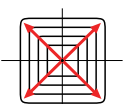

Type V Sq. M

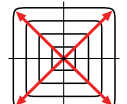

Type V Sq. W

\* Asymmetric optics field rotatable in 90° increments.

## LED Distributions

10 distributions are available to "shape" the output of the LED's to conform to the needs of any roadway or site. Traditional Type II, III, IV, and V - Square patterns are bolstered by variations of those distributions tailored to suit specific needs.

For auto dealerships, the Type II-FR distribution increases illumination on the front row of cars on display and the Type V-SQ-N concentrates more light in a tighter area to enhance the retail effect.

Our Type IV-FT extends the forward throw of illumination to suit the needs of sports facilities (such as tennis courts) by allowing poles to be located outside the field of play.

Standard Type III and Type V-SQ distributions are enhanced with multiple "beamspread" selections (medium and wide Type III's; narrow, medium, and wide Type V-SQ's).

Rotatability of the **PLED**® "panels" allows for the simulation of back-to-back luminaires using only one housing. The Type II-ML arranges standard Type II distributions in a single fixture the same as formerly required by back-to-back luminaire orientation.

## House Side Shield

House side shields are applied to each individual LED in asymmetric distributions and result in outstanding house side cutoff to control property line trespass and unwanted brightness in residential areas.

As with standard **PLED**® panels HS **PLED**® panels may be field rotated in 90° increments and are field replaceable.



House Side Shielding cuts off backlight to less than .1fc at 1/2 mounting height behind pole

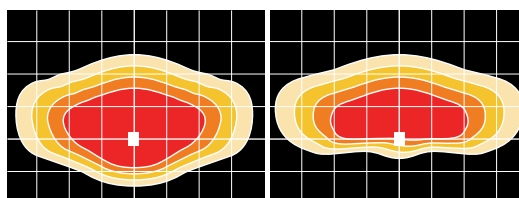

Type II Standard and with House Side Shield

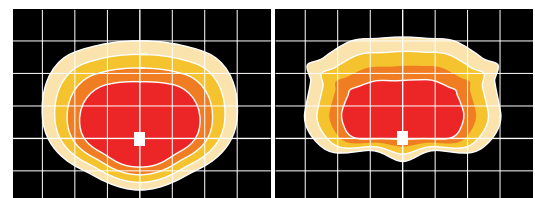

Type IV Standard and with House Side Shield

■ .1 - .2Fc    ■ .2 - .5Fc    ■ .5 - 1Fc    ■ 1Fc and above

# Thermal Management/ Control Options

## LED's are affected by heat in 3 key ways:

- The higher the operating temperature, the shorter the effective LED lifespan.
- Phosphors that create the color temperature of LED's shift their color the hotter the LED operates.
- The higher the LED operating temperature, the less efficient the lumen output of the LED.

Keeping the internal temperature of the LED (called the junction temperature) as low as possible, maximizes LED performance in all these areas.

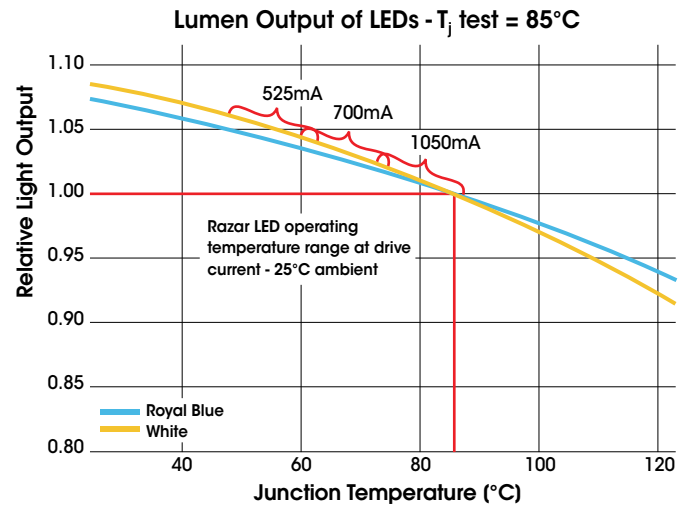

Example of Lumen Output Impact as Junction Temperature rises - 100% Output @ 85°C

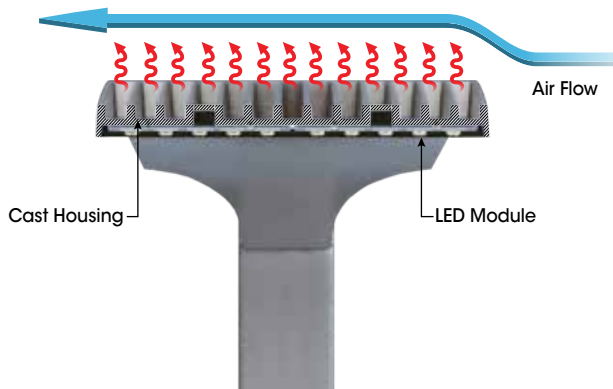

The Razar LED Generation Optical Housing is cast of an A356 aluminum alloy that conducts heat 30% more efficiently than other popular die-cast aluminum alloys. In addition, the mounting surface of the **PLED** Optics is milled to a flatness of .003" over 12" to allow complete contact of the **PLED** and Optical Housing surfaces promoting outstanding thermal control over the LED's.

## Options for Controlling Razar

**HLSW** - Selecting the HLSW option provides an externally switched circuit for step dimming the luminaire from 50% to 100%. The control may be an external timer, an on/off signal from the building automation system, a master motion sensor or any other digital on/off signal

**TPR7** - Selecting the TPR7 option provides a 7-pin ANSI C136.41 dimming receptacle

**MS-F211** - Selecting this option provides a motion sensor pre-programmed to step dim the fixture from 50% to 100%

In addition, the Razar LED Generation Electrical Housing has the capacity to be called out with a wide variety of wireless control systems provided by others.



## Optical Housing

Low copper (A356 alloy; <0.2% Cu) cast aluminum Optical Housing is over 30% more conductive to heat than most other die cast alloys used today.



RZR-PT1



### PLED Optical Panels

Optical Housing is milled to a flatness of .003" over 12" to provide maximum surface contact with the PLED Optical Panels thereby greatly reducing the junction temperatures of the LED's.

### LED Drivers

Drivers are mounted flush against the electrical compartment housing for maximum heat dissipation and held in place by a quick-release slip-bracket for ease of servicing.

## Surge Protection



Today's energy efficient products rely heavily on electronic circuitry that requires far less power than was used in the past. The sophistication of these components comes with the challenge of being far more sensitive to power fluctuations than legacy products using transformers or core and winding inductors. Fusing offers a measure of protection to wiring, but fuses react too slowly to properly protect electronic HID ballasts and LED drivers.

Surge protectors react quickly to power spikes, absorbing or completely shunting them away from luminaire components. However, unlike fuses, surge protectors are a perishable item. They are rated according to the number and intensity of spike and surges and when that combination of frequency and intensity are reached, they no longer function to protect components down line and must be replaced. Thus, installing surge protectors in easily accessible locations for future maintenance is the prudent course.

U.S. Architectural Lighting supplies a surge protectors with every Razer LED luminaire to insure long term performance.

## Specifications - Razar LED Site/Area

**Optical Housing** - Heavy cast low copper aluminum (A356 alloy; <0.2% copper, minimum wall thickness .188") assembly with integral cooling fins. The Optical Panel mounting surface is milled flat (surface variance  $\pm .003"$ ) to facilitate thermal transfer of heat to housing and cooling fins. Solid barrier wall separates optical and electrical compartments. The optical and electrical compartments are integrated to create one assembly.

**Electrical Housing w/Integrated Arm** - Heavy cast low copper aluminum (A356 alloy; <0.2% copper, minimum wall thickness .188") assembly with integral cooling ribs surrounding the electrical compartment and a flat surface on the top of the arm to accommodate a photocell receptacle. Solid barrier wall separates optical and electrical compartments. The optical compartment and electrical compartment with the integrated support arm combine to create one assembly. Cast and hinged driver assembly cover is integrated with wiring compartment cover.

**PLED™ Optical Modules** - Emitters (LED's) are arrayed on a metal core PCB panel with each emitter located on a copper thermal transfer pad and enclosed by an LED refractor. In asymmetric distributions, a micro-reflector inside the refractor re-directs the house side emitter output towards the street side and functions as a house side shielding element. Refractors are injection molded H12 acrylic. Each LED refractor is sealed to the PCB over an emitter and all refractors are retained by an aluminum frame. Any one Panel, or group of Panels in a luminaire, have the same optical pattern. LED refractors produce a variety of site/area distributions. Panels are field replaceable and field rotatable in 90° increments.

**LED Driver(s)** - Constant current electronic with a power factor of >.90 and a minimum operating temperature of -22°F. Driver(s) is/are UL and cUL recognized and mounted directly against the Electrical Housing to facilitate thermal transfer, held down by universal clamps to facilitate easy removal. In-line terminal blocks facilitate wiring between the driver and optical arrays. Drivers accept an input of 120-277V, 50/60Hz. (0 - 10V dimmable driver is standard. Driver has a minimum of 3KV internal surge protection. 20KA surge protector supplied for installation by other.)

**Finish** - Electrostatically applied TGIC Polyester Powder Coat on substrate prepared with 20 PSI power wash at 140°F. Four step media blast and iron phosphate pretreatment for protection and paint adhesion. 400°F bake for maximum hardness and durability. Texture finish is standard.

**Mast Arm Fitter/Electrical Housing** - Replaces standard Electrical Housing. Fits standard 2 3/8" O.D. horizontal tenon. Two (2) straps with two (2) bolts each encircle the lower half of the tenon. Upper half of the tenon rests on self-centering steps that position the angle of the luminaire at 0°, +1.5°, +1.5 or +3° up from the horizontal. All hardware is stainless steel.

### Controlling Options

**HLSW** - Selecting the HLSW option provides an externally switched circuit for step dimming the luminaire from 50% to 100%. The control may be an external timer, an on/off signal from the building automation system, a master motion sensor or any other digital on/off signal.

**TPR7** - Selecting the TPR7 option provides a 7-pin ANSI C136.41 dimming receptacle.

**MS-F211** - Selecting this option provides a motion sensor pre-programmed to step dim the fixture from 50% to 100%.

## Dimensions

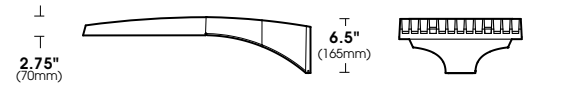
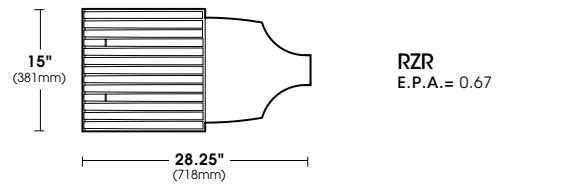
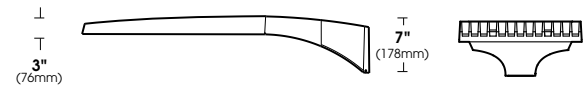
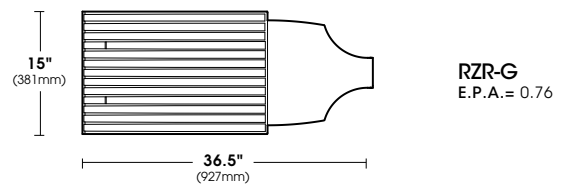

Scale: 1/2" = 1'-0"



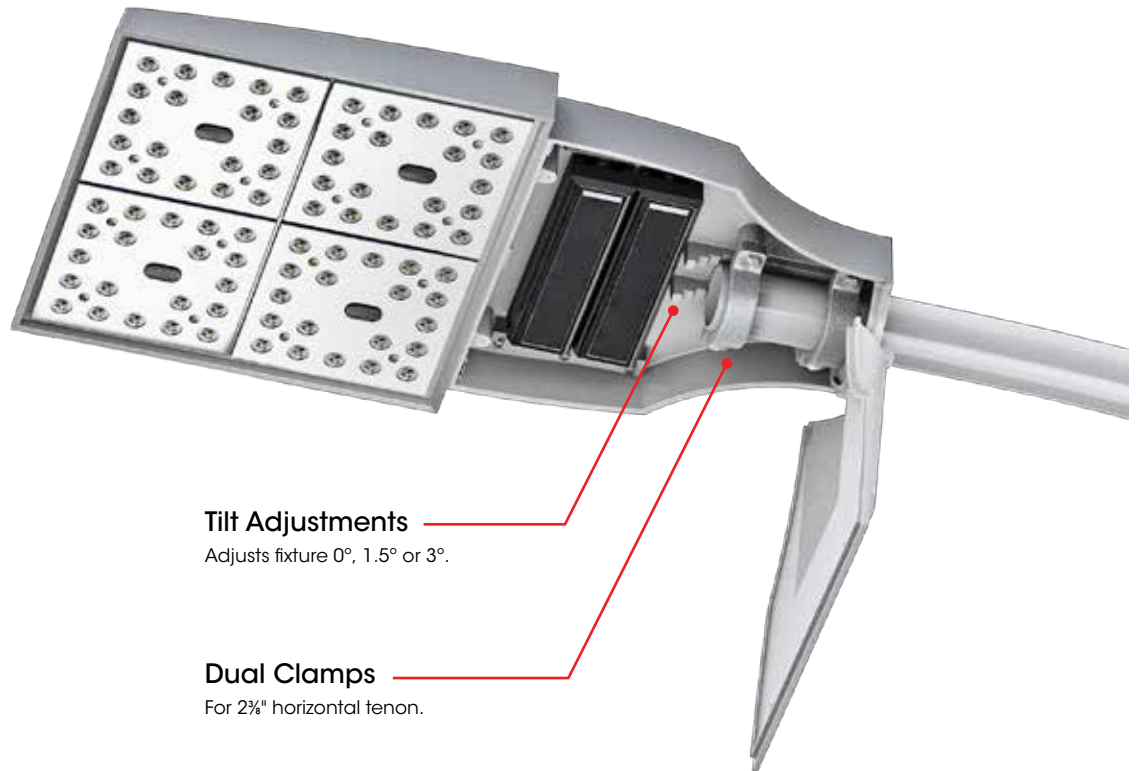











**Tilt Adjustments**

Adjusts fixture 0°, 1.5° or 3°.

**Dual Clamps**

For 2 3/8" horizontal tenon.

Spec/Order Example: RZR/PLED-IV/80LED-700mA/CW/277/RAL-8019-S

MODEL	OPTICS	LED MODE	VOLTAGE	FINISH	OPTIONS
<input type="checkbox"/> RZR-G	<input type="checkbox"/> TYPE II <b>PLED-II</b> .....  <input type="checkbox"/> TYPE II FRONT ROW <b>PLED-II-FR</b> ..... 	<b>RZR-G</b> <input type="checkbox"/> 120LED <input type="checkbox"/> 80LED <input type="checkbox"/> 525mA <input type="checkbox"/> 700mA <input type="checkbox"/> 1050mA	VOLTAGE <input type="checkbox"/> 120 <input type="checkbox"/> 208 <input type="checkbox"/> 240 <input type="checkbox"/> 277 <input type="checkbox"/> 347 <input type="checkbox"/> 480	<b>STANDARD TEXTURED FINISH</b> <input type="checkbox"/> BLACK <b>RAL-9005-T</b> <input type="checkbox"/> WHITE <b>RAL-9003-T</b> <input type="checkbox"/> GREY <b>RAL-7004-T</b> <input type="checkbox"/> DARK BRONZE <b>RAL-8019-T</b> <input type="checkbox"/> GREEN <b>RAL-6005-T</b>  <small>FOR SMOOTH FINISH REPLACE SUFFIX "T" WITH SUFFIX "S" (EXAMPLE: RAL-9005-S)</small>	<input type="checkbox"/> HIGH-LOW DIMMING FOR HARDWIRED SWITCHING OR NONINTEGRATED MOTION SENSOR ..... <b>HLSW</b>  <input type="checkbox"/> INTERNAL HOUSE SIDE SHIELD ... <b>HS-PLED</b>  <input type="checkbox"/> PHOTO CELL + VOLTAGE (EXAMPLE: PC120V) ... <b>PC+V</b>  <input type="checkbox"/> TWIST LOCK PHOTO CELL + VOLTAGE (EXAMPLE: PC120V) ... <b>TPC+V</b>  <input type="checkbox"/> TWIST LOCK RECEPTACLE ONLY ... <b>TPR</b>  <input type="checkbox"/> 7-PIN TWIST LOCK RECEPTACLE ONLY ... <b>TPR7</b>  <input type="checkbox"/> SINGLE FUSE (120V, 277V, 347V) ... <b>SF</b>  <input type="checkbox"/> DOUBLE FUSE (208V, 240V, 480V) ... <b>DF</b>  <input type="checkbox"/> STEP DIM MOTION SENSOR (PROGRAMMED 50/100) ..... <b>MS-F211</b>  <input type="checkbox"/> REMOTE MOTION SENSOR CONFIGURATOR ..... <b>MS-FC10</b>
<input type="checkbox"/> RZR <input type="checkbox"/> RZR-MAF	<input type="checkbox"/> TYPE II MEDIAN ILLUMINATOR <b>PLED-II-ML</b> .....  <input type="checkbox"/> TYPE III MED. <b>PLED-III-M</b> ..... 	<b>RZR</b> <input type="checkbox"/> 80LED <input type="checkbox"/> 40LED	<small>CONSULT FACTORY FOR OTHER LED COLORS</small>		
<input type="checkbox"/> RZRM	<input type="checkbox"/> TYPE III WIDE <b>PLED-III-W</b> .....  <input type="checkbox"/> TYPE IV <b>PLED-IV</b> .....  <input type="checkbox"/> TYPE IV <b>PLED-IV-FT</b> .....  <input type="checkbox"/> TYPE V NARROW <b>PLED-V-SQ-N</b> .....  <input type="checkbox"/> TYPE V MED. <b>PLED-V-SQ-M</b> .....  <input type="checkbox"/> TYPE V WIDE <b>PLED-V-SQ-W</b> ..... 	<b>RZRM</b> <input type="checkbox"/> 48LED <input type="checkbox"/> 24LED		<small>CONSULT FACTORY FOR CUSTOM COLORS</small>	

## Specifications - Razar LED Site/Area

### Razar LED Single Arm Post Top

**Optical/Electrical Housing** - Heavy cast low copper aluminum (A356 alloy; <0.2% copper) assembly with integral cooling fins. The Optical Panel mounting surface is milled flat (surface variance  $<\pm .003"$ ) to facilitate thermal transfer of heat to housing and cooling fins. Solid barrier wall separates optical and electrical compartments. The optical and electrical compartments are integrated to create one assembly. Minimum wall thickness is .188".

**Single Arm Post Top Mounting** - A single, heavy wall cast aluminum arm (A356 alloy, <0.2% copper) connects the Optical/Electrical Housing to the slip fitter hub. Arm is triangular in cross-section transitioning from the apex facing to the pole centerline at the hub to the apex facing outward at the fixture body. Field wiring is accessed through a cover at the mounting hub. Tenon maximum  $2\frac{7}{8}"$  diameter x  $3\frac{1}{2}"$  height. All exposed hardware is stainless steel.

### Razar LED Twin Arm Post Top

**Optical Housing** - Heavy cast low copper aluminum (A356 alloy; <0.2% copper) assembly with integral cooling fins. The Optical Panel mounting surface is milled flat (surface variance  $<\pm .003"$ ) to facilitate thermal transfer of heat to housing and cooling fins. Minimum wall thickness is .188". All hardware is stainless steel.

**Twin Arm Post Top Mounting/Electrical Compartment** - Two (2)  $\frac{1}{2}"$  Sch.40 round aluminum arms are welded to a cast low copper aluminum (A356 alloy; <0.2% Cu) pole top tenon fitter which also serves as the LED Driver and wiring compartment. Tenon maximum  $2\frac{7}{8}"$  diameter x  $3\frac{1}{2}"$  height. All exposed hardware is stainless steel.

**PLED™ Optical Modules** - Emitters (LED's) are arrayed on a metal core PCB panel with each emitter located on a copper thermal transfer pad and enclosed by an LED refractor. In asymmetric distributions, a micro-reflector inside the refractor re-directs the house side emitter output towards the street side and functions as a house side shielding element. Refractors are injection molded H12 acrylic. Each LED refractor is sealed to the PCB over an emitter and all refractors are retained by an aluminum frame. Any one Panel, or group of Panels in a luminaire, have the same optical pattern. LED refractors produce a variety of site/area distributions. Panels are field replaceable and field rotatable in  $90^\circ$  increments.

**LED Driver(s)** - Constant current electronic with a power factor of  $>.90$  and a minimum operating temperature of  $-22^\circ\text{F}$ . Driver(s) is/are UL and cUL recognized. In-line terminal blocks facilitate wiring between the driver and optical arrays. Drivers accept an input of 120-277V, 50/60Hz. (0 - 10V dimmable driver is standard. Driver has a minimum of 3KV internal surge protection. 20KA surge protector supplied for installation by other.)

**Finish** - Electrostatically applied TGIC Polyester Powder Coat on substrate prepared with 20 PSI power wash at  $140^\circ\text{F}$ . Four step media blast and iron phosphate pretreatment for protection and paint adhesion.  $400^\circ\text{F}$  bake for maximum hardness and durability. Texture finish is standard.

### Controlling Options

**HLSW** - Selecting the HLSW option provides an externally switched circuit for step dimming the luminaire from 50% to 100%. The control may be an external timer, an on/off signal from the building automation system, a master motion sensor or any other digital on/off signal.

**TPR7** - Selecting the TPR7 option provides a 7-pin ANSI C136.41 dimming receptacle.





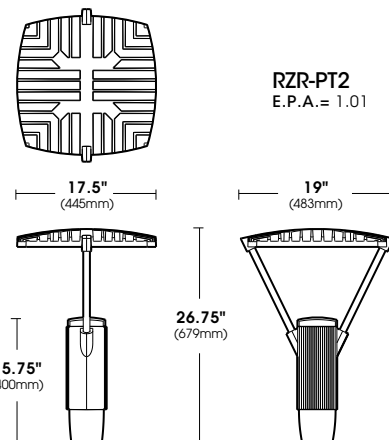
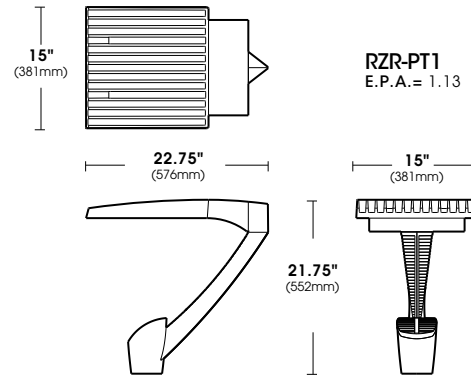





**MS-F211** - Selecting this option provides a motion sensor pre-programmed to step dim the fixture from 50% to 100%.

## Dimensions













Scale:  $1/2" = 1'-0"$

Spec/Order Example: RZR-PT1/PLED-II-ML/40LED-525mA/NW/208/RAL-9005-T/TPR

MODEL	OPTICS	LED MODE			VOLTAGE	FINISH	OPTIONS
<input type="checkbox"/> RZR-PT1	<input type="checkbox"/> TYPE II PLED-II . . . . . 	<input type="checkbox"/> 80LED	<input type="checkbox"/> 350mA	<input type="checkbox"/> NW (4000K)* *STANDARD	<input type="checkbox"/> 120	<b>STANDARD TEXTURED FINISH</b>  <input type="checkbox"/> BLACK RAL-9005-T  <input type="checkbox"/> WHITE RAL-9003-T  <input type="checkbox"/> GREY RAL-7004-T  <input type="checkbox"/> DARK BRONZE RAL-8019-T  <input type="checkbox"/> GREEN RAL-6005-T  <small>FOR SMOOTH FINISH REPLACE SUFFIX "T" WITH SUFFIX "S" (EXAMPLE: RAL-9005-S)</small>  <small>CONSULT FACTORY FOR CUSTOM COLORS</small>	<input type="checkbox"/> HIGH-LOW DIMMING FOR HARDWIRED SWITCHING OR NONINTEGRATED MOTION SENSOR . . . . . HLSW
	<input type="checkbox"/> TYPE II FRONT ROW PLED-II-FR . . . . . 		<input type="checkbox"/> 40LED				<input type="checkbox"/> 525mA
	<input type="checkbox"/> TYPE II MEDIAN ILLUMINATOR PLED-II-ML . . . . . 	<input type="checkbox"/> 700mA	<input type="checkbox"/> 240	<input type="checkbox"/> PHOTO CELL + VOLTAGE (EXAMPLE: PC120V) . . PC+V			
	<input type="checkbox"/> TYPE III PLED-III-M . . . . . 	<input type="checkbox"/> 1050mA (40LED ONLY) <small>CONSULT FACTORY FOR OTHER LED COLORS</small>	<input type="checkbox"/> 277	<input type="checkbox"/> TWIST LOCK PHOTO CELL + VOLTAGE (EXAMPLE: PC120V) . . TPC+V			
	<input type="checkbox"/> TYPE III PLED-III-W . . . . . 		<input type="checkbox"/> 347	<input type="checkbox"/> TWIST LOCK RECEPTACLE ONLY . . . TPR			
	<input type="checkbox"/> TYPE IV PLED-IV . . . . . 		<input type="checkbox"/> 480	<input type="checkbox"/> 7-PIN TWIST LOCK RECEPTACLE ONLY . . . TPR7			
	<input type="checkbox"/> TYPE IV PLED-IV-FT . . . . . 			<input type="checkbox"/> SINGLE FUSE (120V, 277V, 347V) . . SF			
	<input type="checkbox"/> TYPE V NARROW PLED-V-SQ-N . . . . . 			<input type="checkbox"/> DOUBLE FUSE (208V, 240V, 480V) . . DF			
	<input type="checkbox"/> TYPE V PLED-V-SQ-M . . . . . 			<input type="checkbox"/> STEP DIM MOTION SENSOR (PROGRAMMED 50/100) . . . . . MS-F211			
	<input type="checkbox"/> TYPE V PLED-V-SQ-W . . . . . 			<input type="checkbox"/> REMOTE MOTION SENSOR CONFIGURATOR . . . . . MS-FC10			

Spec/Order Example: RZR-PT2/PLED-IV/80LED-700mA/CW/277/RAL-8019-S

MODEL	OPTICS	LED MODE			VOLTAGE	FINISH	OPTIONS
<input type="checkbox"/> RZR-PT2	<input type="checkbox"/> TYPE II PLED-II . . . . . 	<input type="checkbox"/> 80LED	<input type="checkbox"/> 350mA	<input type="checkbox"/> NW (4000K)* *STANDARD	<input type="checkbox"/> 120	<b>STANDARD TEXTURED FINISH</b>  <input type="checkbox"/> BLACK RAL-9005-T  <input type="checkbox"/> WHITE RAL-9003-T  <input type="checkbox"/> GREY RAL-7004-T  <input type="checkbox"/> DARK BRONZE RAL-8019-T  <input type="checkbox"/> GREEN RAL-6005-T  <small>FOR SMOOTH FINISH REPLACE SUFFIX "T" WITH SUFFIX "S" (EXAMPLE: RAL-9005-S)</small>  <small>CONSULT FACTORY FOR CUSTOM COLORS</small>	<input type="checkbox"/> HIGH-LOW DIMMING FOR HARDWIRED SWITCHING OR NONINTEGRATED MOTION SENSOR . . . . . HLSW
	<input type="checkbox"/> TYPE II FRONT ROW PLED-II-FR . . . . . 		<input type="checkbox"/> 40LED				<input type="checkbox"/> 525mA
	<input type="checkbox"/> TYPE II MEDIAN ILLUMINATOR PLED-II-ML . . . . . 	<input type="checkbox"/> 700mA	<input type="checkbox"/> 240	<input type="checkbox"/> PHOTO CELL + VOLTAGE (EXAMPLE: PC120V) . . PC+V			
	<input type="checkbox"/> TYPE III PLED-III-M . . . . . 	<input type="checkbox"/> 1050mA (40LED ONLY) <small>CONSULT FACTORY FOR OTHER LED COLORS</small>	<input type="checkbox"/> 277	<input type="checkbox"/> TWIST LOCK PHOTO CELL + VOLTAGE (EXAMPLE: PC120V) . . TPC+V			
	<input type="checkbox"/> TYPE III PLED-III-W . . . . . 		<input type="checkbox"/> 347	<input type="checkbox"/> TWIST LOCK RECEPTACLE ONLY . . . TPR			
	<input type="checkbox"/> TYPE IV PLED-IV . . . . . 		<input type="checkbox"/> 480	<input type="checkbox"/> 7-PIN TWIST LOCK RECEPTACLE ONLY . . . TPR7			
	<input type="checkbox"/> TYPE IV PLED-IV-FT . . . . . 			<input type="checkbox"/> SINGLE FUSE (120V, 277V, 347V) . . SF			
	<input type="checkbox"/> TYPE V NARROW PLED-V-SQ-N . . . . . 			<input type="checkbox"/> DOUBLE FUSE (208V, 240V, 480V) . . DF			
	<input type="checkbox"/> TYPE V PLED-V-SQ-M . . . . . 			<input type="checkbox"/> STEP DIM MOTION SENSOR (PROGRAMMED 50/100) . . . . . MS-F211			
	<input type="checkbox"/> TYPE V PLED-V-SQ-W . . . . . 			<input type="checkbox"/> REMOTE MOTION SENSOR CONFIGURATOR . . . . . MS-FC10			

# Proportion Visualizer

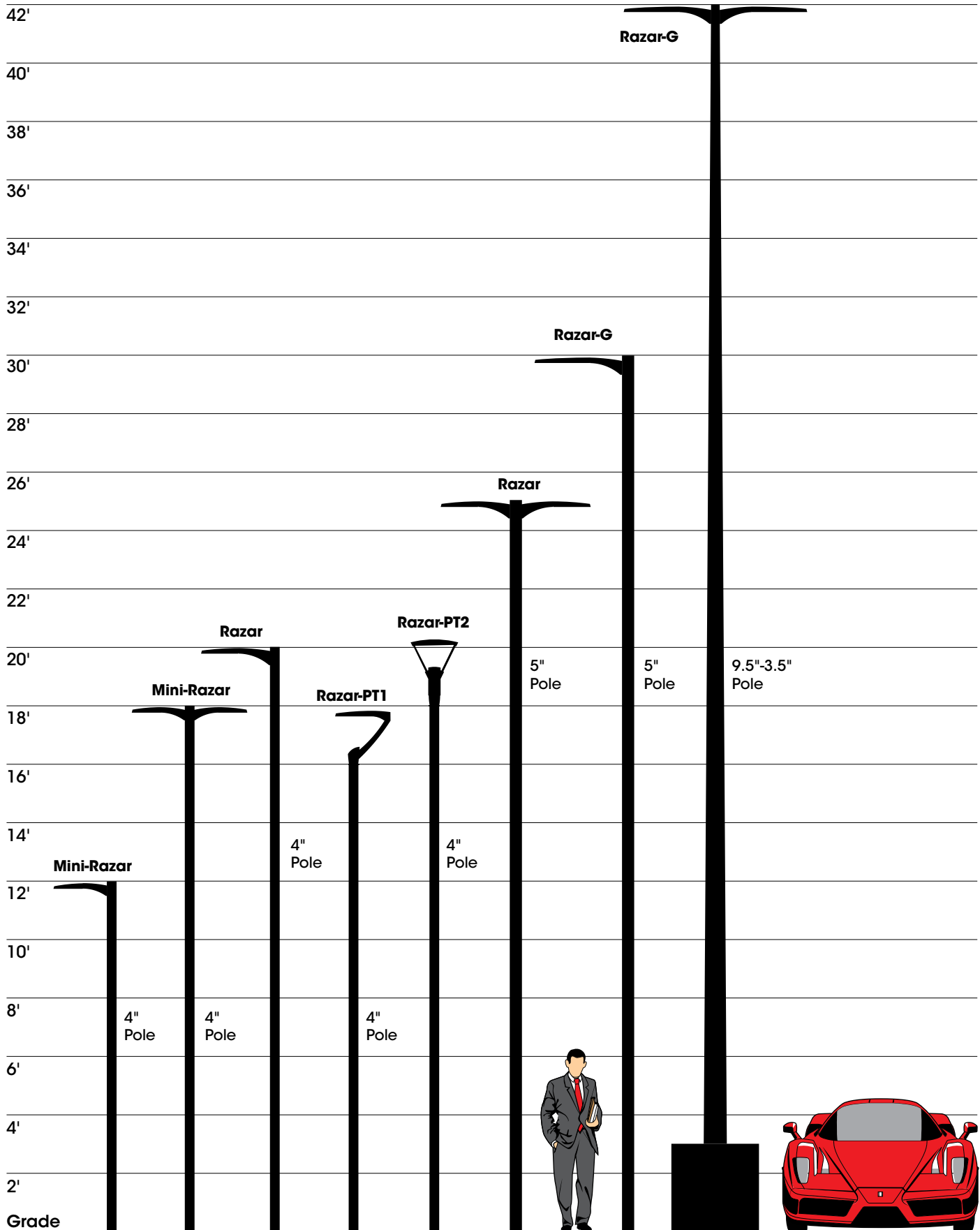

# Razar LED Wall Mount

## Wall Mounted

The Razar LED Wall Mount extends the family of Razar LED luminaires to be application specific. U.S. Architectural Lighting designed and engineered the Razar electrical compartment for specific wall mounting adds elegance and architectural relevance to the Razar LED luminaire.

The Razar LED Wall Mount electrical housing appears to organically reach out from the mounting surface to capture the optical assembly and create the impression of a luminaire that is a natural extension of the building structure.



As light level requirements increase, Razar LED Wall Mount extends laterally to include one, two or three optical modules and can be selected with 4 standard drive currents. The result is a luminaire that can equal the task requirements from a 35W PSMH lamp up to a 400W PSMH lamp while extending only 12" from the wall (14" for EM application), retaining the aesthetic focus on the architecture rather than the luminaire. All the while creating a continuity of design in all the elements illuminating the site

Razar LED Wall Mount is ideal whether lighting intimate use locations that have security concerns like an ATM station or providing pathway illumination around campus and retail sites where poles would congest the visual environment. In its largest and highest output form, Razar LED Wall Mount with its multiple distributions is more than up to the task of lighting high traffic areas like truck aprons and loading docks that require access by large truck and trailers where poles would interfere and site requirements need maximum optical flexibility.



RZR-WM1



RZR-WM2



RZR-WM3



## Available Light Distributions

Five different asymmetric patterns make the Razar LED Wall Mount a powerful tool for lighting acreage around the building structure. Rotatable optics add to that flexibility and allow unique conditions to be lit with ease.

Additionally, optional **house side shielding** reduces the intensity of backlight on the building surface and a 5° front shield reduce high angle brightness visible off site.

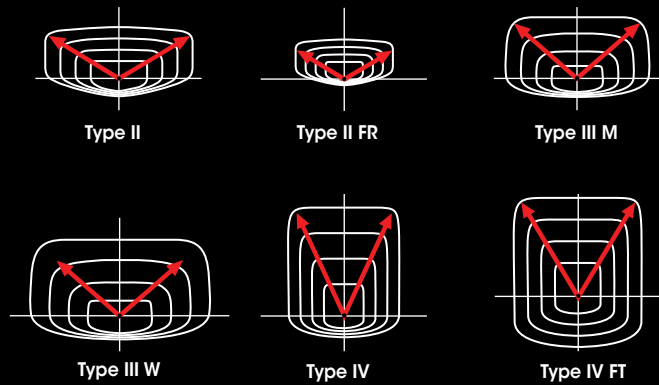

## Visual Efficacy

**Razar LED Wall Mount** also has the same lumen packages available across multiple housing sizes. This feature puts the specifier in control of the visual efficacy (brightness + glare).

Consider: An RZR-WM1 specified with a 700mA drive current will have the same lumen output as an RZR-WM2 with a 350mA drive current. Similarly, an RZR-WM1 at 1050mA has the same lumen output as an RZR-WM3 at 350mA.

By selecting the smaller luminaire with the lower LED count and higher drive current, costs are kept at a minimum. Selecting the RZR-WM2 or RZR-WM3 in the foregoing example however, will considerably reduce the perceived brightness of the optical system by "spreading" the lumens over a greater number of LED's.

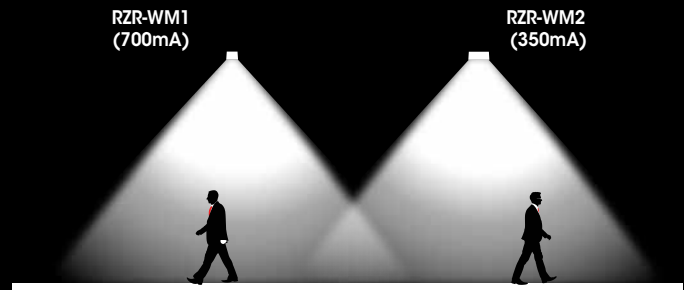

**Less Glare.** Looking directly at a clear, lit PSMH lamp can be uncomfortable due to its brightness and the resultant glare.



Looking at a coated, lit PSMH lamp, while still bright, is much more comfortable as the lumens are spread over the entire surface of the bulb.



In a similar manner, "spreading" the lumen output over a greater number of LED's mitigates fixture brightness.

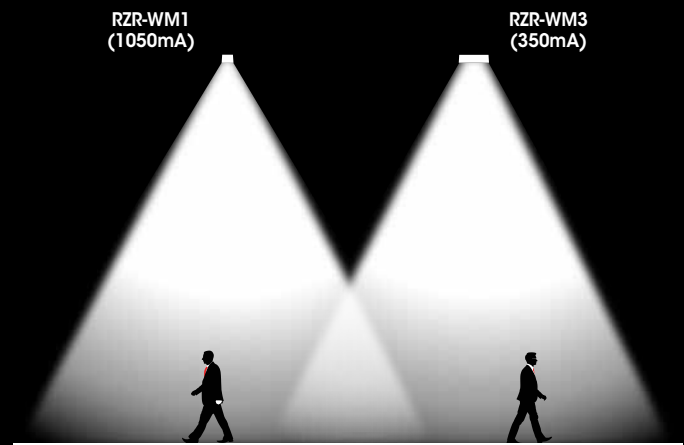

## Additional Options

When using the EM-LED option, the **Razar LED Wall Mount** electrical compartment is extended an additional 2" to allow room for the emergency driver and batteries to be contained within the fixture. The EM-LED system provides power to the LED array to meet the following light levels for a minimum of 90 minutes -

- WM1 = 45% @ 350mA
- WM2 = 36% @ 350mA
- WM3 = 24% @ 350mA

\*Multiply the % above by the lumen output @ 350mA

Some building applications require the use of surface conduit. In these applications, the electrical compartment extension is provided with provisions for one 3/4" conduit entry on either side of the housing and one entry on the bottom. Specify a SC-RZWM.



Emergency Option



Surface Conduit

## Specifications - Razar LED Wall Mounted

**Optical Housing** - Heavy cast low copper aluminum (A356 alloy; <0.2% copper) assembly with integral cooling fins. The Optical Panel mounting surface is milled flat (surface variance <± .003") to facilitate thermal transfer of heat to housing and cooling fins. The Optical Housing bolts to the Electrical Housing forming a unified assembly. The minimum wall thickness is .188".

**Electrical Housing** - Heavy cast low copper aluminum (A356 alloy; <0.2% copper) assembly. Minimum wall thickness is .188". Fixture Mounting Plate affixes to mounting surface over a recessed j-box. Electrical Housing anchors on the top edge of the Mounting Plate and stainless steel recessed socket head screws tighten the Electrical Housing to the Mounting Plate from the bottom.

**PLED™ Optical Modules** - Emitters (LED's) are arrayed on a metal core PCB panel with each emitter located on a copper thermal transfer pad and enclosed by an LED refractor. The asymmetric distributions, have a micro-reflector inside the refractor which re-directs the house side emitter output towards the street side and functions as a house side shielding element. Refractors are injection molded H12 acrylic. Each LED refractor is sealed to the PCB over an emitter and all refractors are retained by an aluminum frame. Any one Panel, or group of Panels in a luminaire, have the same optical pattern. LED refractors produce Type II, III, and Type IV site/area distributions as well as other specialty asymmetric distributions. Panels are field replaceable and field rotatable in 90° increments.

**LED Driver(s)** - Constant current electronic with a power factor of >.90 and a minimum operating temperature of -22°F. Driver(s) is/are UL and cUL recognized and mounted to a driver assembly plate that has slotted holes to facilitate ease of assembly removal for fixture installation. Quick disconnects for incoming power and optical assembly power are provided. Drivers accept an input of 120-277V, 50/60Hz and utilize 0-10V dimming. 347V-480V, 50,60Hz also available on some models. Surge protector supplied for field installation at the most conveniently serviceable location.

**LED Emitters** - High output LED's are utilized with drive currents ranging from 350mA to 1050mA. 70CRI Minimum. LED's are available in standard Neutral White (4000K), or optional Cool White (5000K) or Warm White (3000K). Consult Factory for other LED options.

**Finish** - Electrostatically applied TGIC Polyester Powder Coat on substrate prepared with 20 PSI power wash at 140°F. Four step media blast and iron phosphate pretreatment for protection and paint adhesion. 400°F bake for maximum hardness and durability.

## Dimensions

Refer to the Razar LED Wall Mount spec sheet for mounting information.

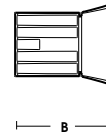

	A	B	C
RZR-WM1	8.75" (22mm)	12" (305mm)	6" (152mm)
RZR-WM1-EM	11" (279mm)	14" (356mm)	6.5" (165mm)



RZR-WM1-LED	E.P.A. = .33
-------------	--------------

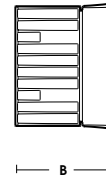

	A	B	C
RZR-WM2	16" (406mm)	12" (305mm)	6" (152mm)
RZR-WM2-EM	16" (406mm)	14" (356mm)	6.5" (165mm)



RZR-WM2-LED	E.P.A. = .47
-------------	--------------

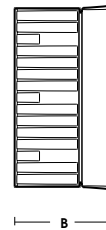

	A	B	C
RZR-WM3	23" (584mm)	12" (305mm)	6" (152mm)
RZR-WM3-EM	23" (584mm)	14" (356mm)	6.5" (165mm)



RZR-WM3-LED	E.P.A. = .69
-------------	--------------

**Spec/Order Example:** RZR-WM2/PLED-IV/40LED-700mA/CW/277/RAL-8019-S/SF

Scale: 1/2" = 1'-0"

MODEL	OPTICS	LED MODE			VOLTAGE	FINISH	OPTIONS
<input type="checkbox"/> RZR-WM1	<b>PLED® DISTRIBUTION TYPE</b> <input type="checkbox"/> TYPE II <b>PLED-II</b> .....	<b>RZR-WM1</b> <input type="checkbox"/> 20LED	<input type="checkbox"/> 350mA <input type="checkbox"/> 525mA	<input type="checkbox"/> NW (4000K)* <small>*STANDARD</small> <input type="checkbox"/> CW (5000K) <input type="checkbox"/> WW (3000K)	<input type="checkbox"/> 120 <input type="checkbox"/> 208 <input type="checkbox"/> 240 <input type="checkbox"/> 277 <input type="checkbox"/> 347 <sup>1</sup> <input type="checkbox"/> 480 <sup>1</sup>	<b>STANDARD TEXTURED FINISH</b> <input type="checkbox"/> BLACK <b>RAL-9005-T</b> <input type="checkbox"/> WHITE <b>RAL-9003-T</b> <input type="checkbox"/> GREY <b>RAL-7004-T</b> <input type="checkbox"/> DARK BRONZE <b>RAL-8019-T</b> <input type="checkbox"/> GREEN <b>RAL-6005-T</b>	<input type="checkbox"/> HIGH-LOW DIMMING FOR EXTERNAL CONTROL ... <b>HL5W</b> <input type="checkbox"/> HOUSE SIDE SHIELDING ..... <b>HS-PLED</b> <input type="checkbox"/> PHOTO CELL + VOLTAGE (EXAMPLE: PC120V) ... <b>PC+V</b> <input type="checkbox"/> SINGLE FUSE (120V & 277V) ..... <b>SF</b> <input type="checkbox"/> DOUBLE FUSE (208V & 240V) ..... <b>DF</b> <input type="checkbox"/> EMERGENCY BACKUP 1. <b>EM1</b> <input type="checkbox"/> EMERGENCY BACKUP 1 (HOUSING ONLY) ... <b>EMH1</b> <input type="checkbox"/> EMERGENCY BACKUP 2. <b>EM2</b> <input type="checkbox"/> EMERGENCY BACKUP 2 (HOUSING ONLY) ... <b>EMH2</b> <input type="checkbox"/> EMERGENCY BACKUP 3. <b>EM3</b> <input type="checkbox"/> EMERGENCY BACKUP 3 (HOUSING ONLY) ... <b>EMH3</b> <input type="checkbox"/> SURFACE CONDUIT 1. ... <b>SC1</b> <input type="checkbox"/> SURFACE CONDUIT 2. ... <b>SC2</b> <input type="checkbox"/> SURFACE CONDUIT 3. ... <b>SC3</b>
<input type="checkbox"/> RZR-WM2	<input type="checkbox"/> TYPE II FRONT ROW <b>PLED-II-FR</b> ..... <input type="checkbox"/> TYPE III <b>PLED-III-M</b> .....	<b>RZR-WM2</b> <input type="checkbox"/> 40LED	<input type="checkbox"/> 700mA <input type="checkbox"/> 1050mA	<small>CONSULT FACTORY FOR OTHER LED COLORS</small>			
<input type="checkbox"/> RZR-WM3	<input type="checkbox"/> TYPE III <b>PLED-III-W</b> ..... <input type="checkbox"/> TYPE IV <b>PLED-IV</b> ..... <input type="checkbox"/> TYPE IV-FT <b>PLED-IV-FT</b> .....	<b>RZR-WM3</b> <input type="checkbox"/> 60LED					

**NOTE:**  
 1 - NOT AVAILABLE IN RZR-WM1.  
 CONSULT FACTORY

FOR SMOOTH FINISH REPLACE SUFFIX "T" WITH SUFFIX "S" (EXAMPLE: RAL-9005-S)  
 CONSULT FACTORY FOR CUSTOM COLORS





# Razar LED Bollard

## Bollard



The shape of the Razar LED Bollard immediately identifies the direction of its illumination pattern. A wide variety of asymmetric distributions allows tailoring the lighting distribution for any site requirements and for illuminating narrow walkways or wide, open plaza spaces.

The robust construction of the Razar LED Bollard imparts durability in any application and addresses the heat dissipation needs of its LED source. Thermal efficiency and relatively low drive currents keep the LED module temperatures well below normal LED design parameters. In fact, the Razar LED Bollard housing will heat up more on a summer's day from sunlight radiation than at night from the LED's.

Available in single and twin head configurations, when matched with the various distributions, the solutions presented will satisfy every pathway illumination need. To illustrate the unique capabilities of the Razar LED Bollard, look at the RZR B2. Illumination on one side from a Type II distribution can light a walkway and on the other side, a Type IV distribution can extend the pattern out from the edge of the pathway to illuminate a large landscaped area thereby providing additional nighttime security.

### Illumination Characteristics

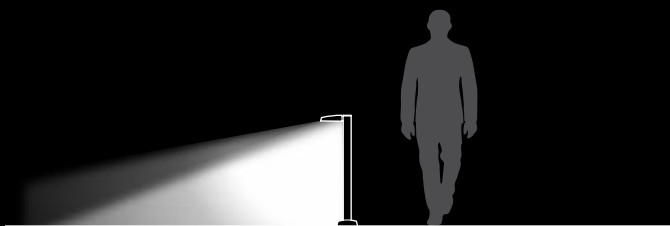

The RZR B1 model produces an asymmetric light distribution which is clearly expressed by its form. It is ideal for pathways and driveways where illumination is desired from the perimeters. These bollards define visual direction and boundaries for both people and vehicles. The light source, whether LED, HID or compact fluorescent, is concealed from any view above horizontal.

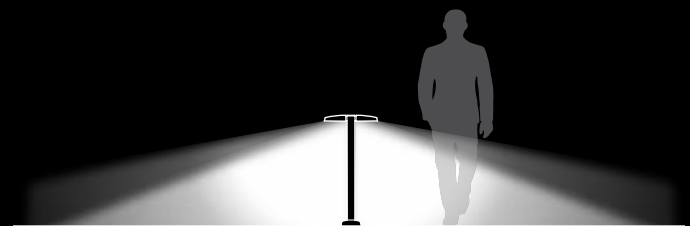

The RZR B2 model is a direct companion to the RZR B1, as both models are typically used on the same project. The RZR B2 produces a symmetric light pattern for open areas where illumination is required on all sides of the bollard. Even when located along pathways, the RZR B2 can illuminate both hardscape on one side, and landscape on the opposite side.

## Heat Management

Low drive currents combined with superior heat conduction technology keeps the LED internals at half their rated maximum operating temperature. Generous and robust cooling fins provide a distinctive appearance to the **Razar LED Bollard** and also keep surface temperatures low enough to touch even after hours of operation.

## Optical Module

**Razar LED Bollard** is engineered to use the same PLED optical modules as the Razar LED pole mounted luminaire with all its high performance optics. Five asymmetric distributions provide ultimate flexibility in application to satisfy the needs of any site.

## Riser

The heavy-walled durable extruded aluminum riser is the ideal platform for the optical assemblies. Its robust construction will reliably withstand the rigors of pathway lighting.

## Base and Base Cover

As the foundation for the entire assembly, the base of the **Razar LED Bollard** again shows thoroughness in design and engineering. The cover is cast as a single piece and installed during the assembly of the fixture to insure a clean, seamless appearance and is locked to the base with stainless steel socket headed cap screws. The design-coordinated base cover hides the ingenious anchor assembly that utilizes bolts threaded into female couplers poured into the concrete base. There's no guessing about bolt projections. (See the Anchor Bolt Assembly)

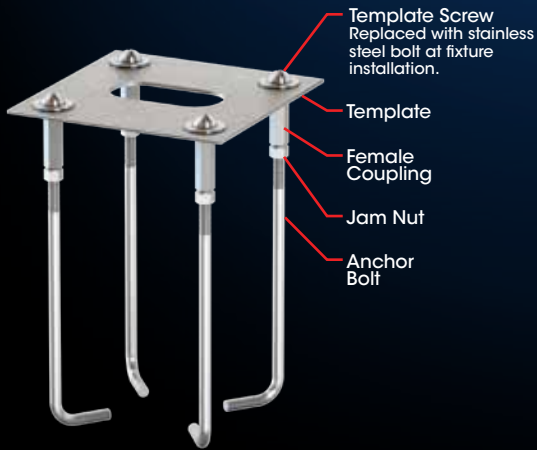

## Anchor Bolt Assembly

Anchor bolts, couplers, and template are shipped as an assembly. Place the assembly in concrete and once set, remove the screws holding down the template. The **Razar LED Bollard** base will then bolt down to the couplers.

## Specifications - Razar LED Bollards

**Optical Housing** - Heavy cast low copper aluminum (A356 alloy; <0.2% copper) assembly with integral cooling fins. The Optical Panel mounting surface is milled flat (surface variance <math>\pm .003''</math>) to facilitate thermal transfer of heat to housing and cooling fins. Minimum wall thickness is .188".

**Shaft & Base** - Extruded aluminum (6061-T6 alloy) riser welded to heavy cast aluminum (A356 alloy; <0.2% copper) base. Riser has minimum wall thickness of .188". Electrical assembly including LED mains driver, LED Emergency driver (optional LED-EM) with batteries, and quick connectors suspended inside riser. Concealed bolts attach the Optical Housing bolts to Riser.

**Anchor Bolts** - Four 3/8" x 10" x 2" galvanized anchor bolts with couplings, leveling nuts, washers, template, and stainless bolts.

**PLED™ Optical Modules** - Emitters (LED's) are arrayed on a metal core PCB panel with each emitter located on a copper thermal transfer pad and enclosed by an LED refractor. The asymmetric distributions have a micro-reflector inside the refractor that re-directs the house side emitter output towards the street side and functions as a house side shielding element. Refractors are injection molded H12 acrylic. Each LED refractor is sealed to the PCB over an emitter and all refractors are retained by an aluminum frame. All refractors in a Panel have the same optical pattern. LED refractors produce standard site/area distributions - Type II, and Type IV. Panels are field replaceable and field rotatable in 90° increments.

**LED Driver(s)** - Constant current electronic with a power factor of >.90 and a minimum operating temperature of -22°F. Driver is UL and cUL recognized and mounted to a retaining bracket suspended inside the Riser. In-line terminal blocks facilitate wiring between the driver and optical arrays. Drivers accept an input of 120-277V, 50/60Hz or 347V-480V, 50,60Hz. Optional Emergency LED driver and batteries provide 16w for 90 minutes through the main LED array. 20KV surge protector suitable for field installation provided. (0 - 10V dimmable driver is standard except for RZR B1 @ 175mA)

**LED Emitters** - High output LED's are utilized with drive currents ranging from 175mA to 350mA. 70CRI Minimum. LED's are available in standard Neutral White (4000K), or optional Cool White (5000K) or Warm White (3000K). Consult Factory for other LED options.

**Finish** - Electrostatically applied TGIC Polyester Powder Coat on substrate prepared with 20 PSI power wash at 140°F. Four step media blast and iron phosphate pretreatment for protection and paint adhesion. 400°F bake for maximum hardness and durability.

## Dimensions

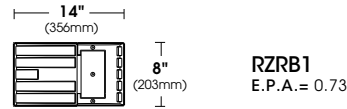

**RZR B1**  
E.P.A. = 0.73

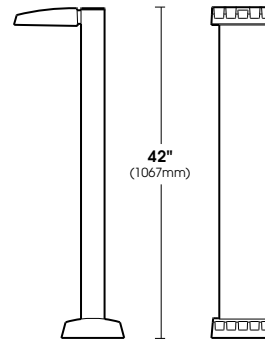

# OF LED'S	MAX INPUT WATTAGE			
	DRIVE CURRENT			
20	175mA	HID EQUIV	350mA	HID EQUIV
	12W	50W	22W	70W

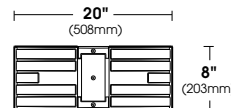

**RZR B2**  
E.P.A. = 0.81

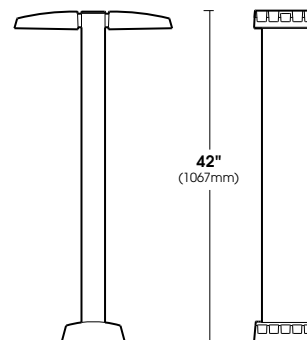

# OF LED'S	MAX INPUT WATTAGE			
	DRIVE CURRENT			
40	175mA	HID EQUIV	350mA	HID EQUIV
	22W	50W	44W	70W

**Spec/Order Example:** RZR B2/PLED-II/40PLED-175mA/NW/277/RAL-9005-T

Scale: 1/2" = 1'-0"

MODEL	OPTICS	LED MODE			VOLTAGE	FINISH	OPTIONS
<input type="checkbox"/> RZR B1	<b>PLED® DISTRIBUTION TYPE</b> <input type="checkbox"/> TYPE II <b>PLED-II</b> .....	<b>NO. LED'S</b> <b>RZR B1<sup>1</sup></b> <input type="checkbox"/> 20LED	<b>DRIVE CURRENT</b> <input type="checkbox"/> 175mA <sup>1</sup> <input type="checkbox"/> 350mA	<b>COLOR TEMP - CCT</b> <input type="checkbox"/> NW (4000K)* *STANDARD <input type="checkbox"/> CW (5000K) <input type="checkbox"/> WW (3000K) OTHER LED COLORS AVAILABLE CONSULT FACTORY	<b>VOLTAGE</b> <input type="checkbox"/> 120 <input type="checkbox"/> 208 <input type="checkbox"/> 240 <input type="checkbox"/> 277 <input type="checkbox"/> 347 <input type="checkbox"/> 480	<b>STANDARD TEXTURED FINISH</b> <input type="checkbox"/> BLACK <b>RAL-9005-T</b> <input type="checkbox"/> WHITE <b>RAL-9003-T</b> <input type="checkbox"/> GREY <b>RAL-7004-T</b> <input type="checkbox"/> DARK BRONZE <b>RAL-8019-T</b> <input type="checkbox"/> GREEN <b>RAL-6005-T</b>	<input type="checkbox"/> HOUSE SIDE SHIELDING ..... <b>HS-PLED</b> <input type="checkbox"/> HIGH-LOW DIMMING FOR HARDWIRED SWITCHING OR NON-INTEGRATED MOTION SENSOR ..... <b>HLSW</b> <input type="checkbox"/> SINGLE FUSE (120V & 277V) ..... <b>SF</b> <input type="checkbox"/> DOUBLE FUSE (208V & 240V) ..... <b>DF</b> <input type="checkbox"/> EMERGENCY BACKUP1 .. <b>EM-RZR B1</b> <input type="checkbox"/> EMERGENCY BACKUP2 .. <b>EM-RZR B2</b>
<input type="checkbox"/> RZR B2	<input type="checkbox"/> TYPE II FRONT ROW <b>PLED-II-FR</b> ..... <input type="checkbox"/> TYPE III <b>PLED-III-M</b> ..... <input type="checkbox"/> TYPE III <b>PLED-III-W</b> ..... <input type="checkbox"/> TYPE IV <b>PLED-IV</b> ..... <input type="checkbox"/> TYPE IV <b>PLED-IV-FT</b> .....	<b>RZR B2</b> <input type="checkbox"/> 40LED				FOR SMOOTH FINISH REPLACE SUFFIX "T" WITH SUFFIX "S" (EXAMPLE: RAL-9005-S)  CONSULT FACTORY FOR CUSTOM COLORS	THE EM-LED SYSTEM PROVIDES POWER TO THE LED ARRAY TO MEET THE FOLLOWING LIGHT LEVELS FOR A MINIMUM OF 90 MINUTES:  RZR B1 = 90% @ 175mA RZR B1 = 45% @ 350mA RZR B2 = 50% @ 175mA RZR B2 = 36% @ 350mA  *MULTIPLY THE % ABOVE BY THE LUMEN OUTPUT @ 350mA
		<b>NOTES:</b> 1 - DIMMING NOT AVAILABLE IN RZR B1 AT 175mA DRIVE CURRENT. 2 - CONSULT FACTORY FOR 347V OR 480V OPERATION.					

# Razar LED Generation

The Ultimate in LED Site Illumination



**U.S. ARCHITECTURAL**  
**LIGHTING**

U.S. POLE COMPANY  
660 West Avenue O  
Palmdale, California 93551  
Toll Free (800) 877-6537  
[www.usaltg.com](http://www.usaltg.com)



Patents Pending

0816