

Post Top Tenon Mounted Arm

XAL-PT

Arm

Durable corrosion resistant, cast aluminum construction.

Finish

Electrostatically applied TGIC Polyester Powder Coat on substrate prepared with 20 PSI power wash at 140°F. Four step media blast and iron phosphate pretreatment for protection and paint adhesion. 400°F bake for maximum hardness and durability.



XAL-PT

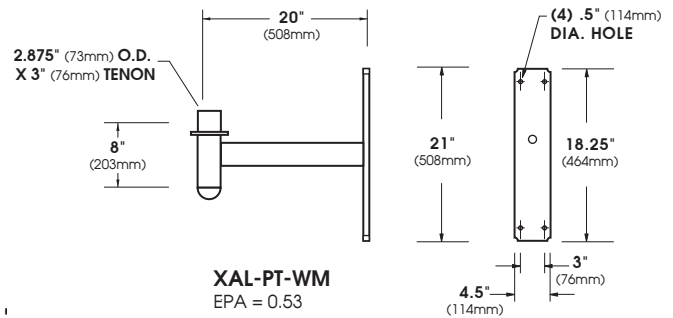
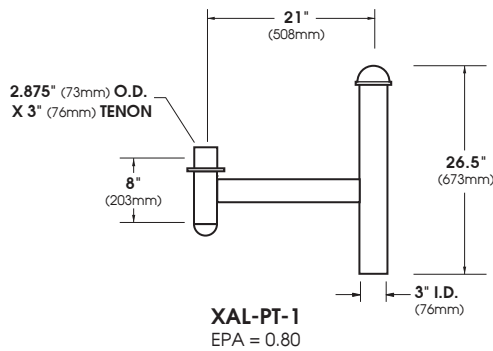
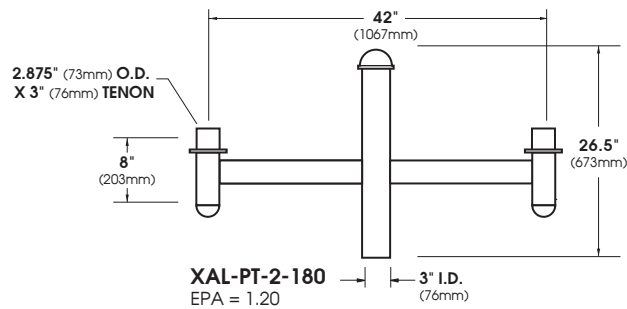

SCALE: 1/2"=1'

ORDERING INFORMATION

Spec/Order Example: XAL-3-180/RAL-7004-T

Configuration								
	<input type="checkbox"/> XAL-PT-WM	<input type="checkbox"/> XAL-PT-1	<input type="checkbox"/> XAL-PT-2-180	<input type="checkbox"/> XAL-PT-3-180	<input type="checkbox"/> XAL-PT-3-120	<input type="checkbox"/> XAL-PT-4-120	<input type="checkbox"/> XAL-PT-4-90	<input type="checkbox"/> XAL-PT-5-90
Finish*	<input type="checkbox"/> Black RAL-9005-T	<input type="checkbox"/> White RAL-9003-T	<input type="checkbox"/> Grey RAL-7004-T	<input type="checkbox"/> Dark Bronze RAL-8019-T	<input type="checkbox"/> Green RAL-6005-T	Premium Finishes		
						<input type="checkbox"/> Rust	<input type="checkbox"/> Patina Copper PC	

*Standard texture finish. For smooth finish replace suffix "T" with suffix "S" (Example: RAL-9005-S)

Consult factory for custom colors