

TENON MOUNTED ARM

XAO

PROJECT NAME: _____

PROJECT TYPE: _____

FEATURES

Arm

Durable corrosion resistant, cast aluminum construction.

Finish

Electrostatically applied TGIC Polyester Powder Coat on substrate prepared with 20 PSI power wash at 140°F. Four step media blast and iron phosphate pretreatment for protection and paint adhesion. 400°F bake for maximum hardness and durability.



XAO

Patent pending

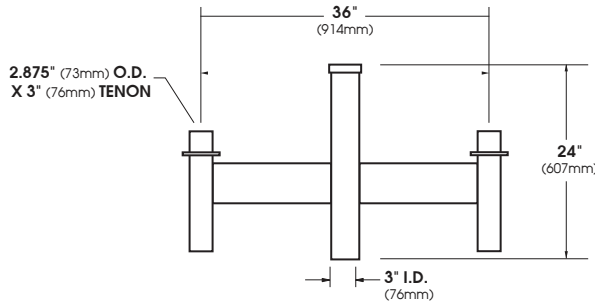

XAO-2-180
EPA = 2.41

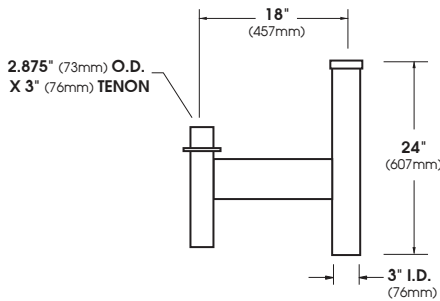

XAO-1
EPA = 1.56

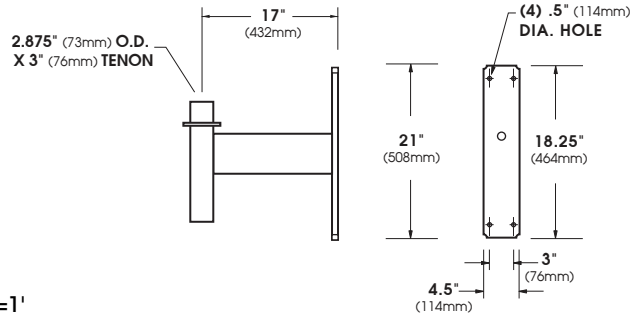

XAO-WM
EPA = 0.98

SCALE: 1/2"=1'

ORDERING INFORMATION

Spec/Order Example: XAO-2-180/RAL-9003-T

Configuration								
	<input type="checkbox"/> XAO-WM	<input type="checkbox"/> XAO-1	<input type="checkbox"/> XAO-2-180	<input type="checkbox"/> XAO-3-180	<input type="checkbox"/> XAO-3-120	<input type="checkbox"/> XAO-4-120	<input type="checkbox"/> XAO-4-90	<input type="checkbox"/> XAO-5-90
Finish*	<input type="checkbox"/> Black RAL-9005-T	<input type="checkbox"/> White RAL-9003-T	<input type="checkbox"/> Grey RAL-7004-T	<input type="checkbox"/> Dark Bronze RAL-8019-T	<input type="checkbox"/> Green RAL-6005-T	*Standard texture finish For smooth finish replace suffix "T" with suffix "S" (Example: RAL-9005-S) Consult factory for custom colors		