

Post Top Tenon Mounted Arm

FEATURES

Arm

Durable corrosion resistant, cast aluminum construction.

Finish

Electrostatically applied TGIC Polyester Powder Coat on substrate prepared with 20 PSI power wash at 140°F. Four step media blast and iron phosphate pretreatment for protection and paint adhesion. 400°F bake for maximum hardness and durability.

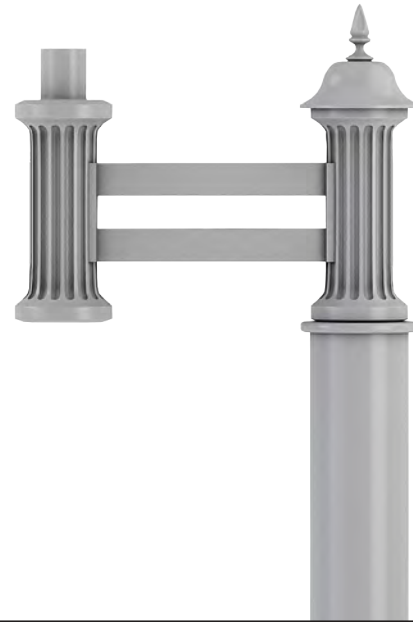

XAV

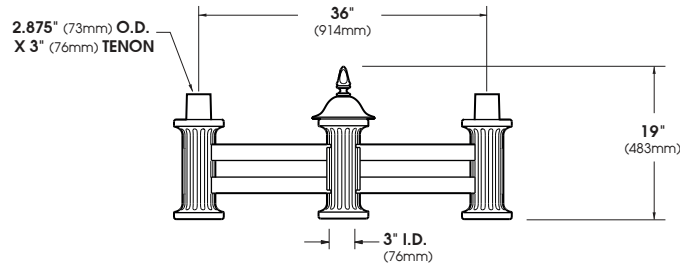

XAV-2-180
EPA = 2.81

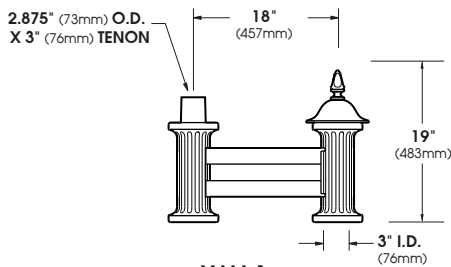

XAV-1
EPA = 1.59

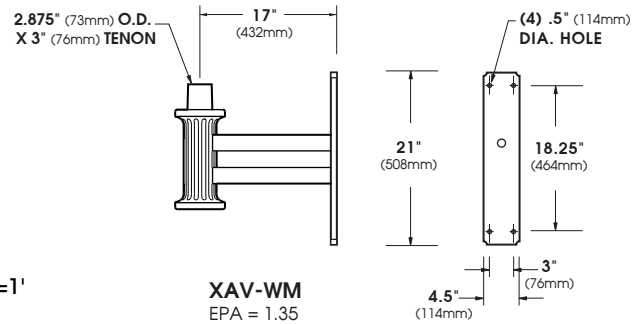

XAV-WM
EPA = 1.35

SCALE: 1/2"=1'

ORDERING INFORMATION

Spec/Order Example: XAV-4-90/RAL-6005-S

Configuration

-  XAV-PT-WM
-  XAV-PT-1
-  XAV-PT-2-180
-  XAV-PT-3-180
-  XAV-PT-3-120
-  XAV-PT-4-120
-  XAV-PT-4-90
-  XAV-PT-5-90

Finish*

- Black RAL-9005-T
- White RAL-9003-T
- Grey RAL-7004-T
- Dark Bronze RAL-8019-T
- Green RAL-6005-T
- Rust
- Patina Copper PC

*Standard texture finish. For smooth finish replace suffix "T" with suffix "S" (Example: RAL-9005-S)

Consult factory for custom colors