

# TENON MOUNTED ARM

# XAX

PROJECT NAME: \_\_\_\_\_

PROJECT TYPE: \_\_\_\_\_

## FEATURES

### Arm

Durable corrosion resistant, cast aluminum construction.

### Finish

Electrostatically applied TGIC Polyester Powder Coat on substrate prepared with 20 PSI power wash at 140°F. Four step media blast and iron phosphate pretreatment for protection and paint adhesion. 400°F bake for maximum hardness and durability.

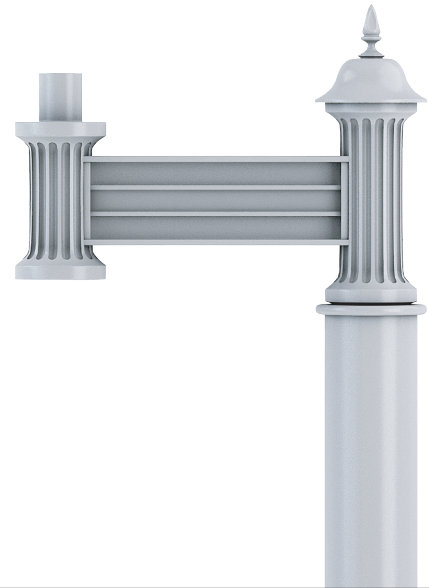

## XAX

Patent pending

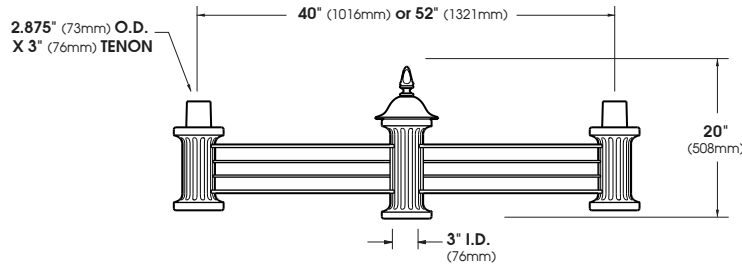

**XAX-2-180**  
EPA = 2.99

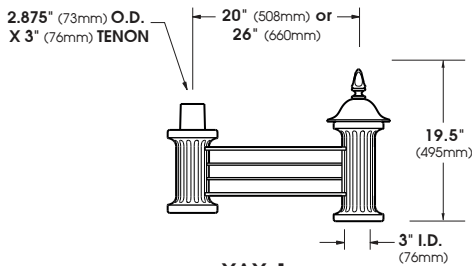

**XAX-1**  
EPA = 1.68

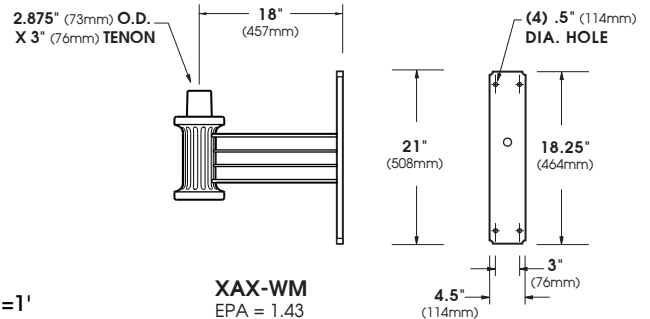









**XAX-WM**  
EPA = 1.43

SCALE: 1/2"=1'

## ORDERING INFORMATION

Spec/Order Example: XAX-3-120/RAL-6005-S

Configuration	<input type="checkbox"/>  XAX-WM	<input type="checkbox"/>  XAX-1	<input type="checkbox"/>  XAX-2-180	<input type="checkbox"/>  XAX-3-180	<input type="checkbox"/>  XAX-3-120	<input type="checkbox"/>  XAX-4-120	<input type="checkbox"/>  XAX-4-90	<input type="checkbox"/>  XAX-5-90
Finish*	<input type="checkbox"/> Black RAL-9005-T	<input type="checkbox"/> White RAL-9003-T	<input type="checkbox"/> Grey RAL-7004-T	<input type="checkbox"/> Dark Bronze RAL-8019-T	<input type="checkbox"/> Green RAL-6005-T	<small>*Standard texture finish For smooth finish replace suffix "T" with suffix "S" (Example: RAL-9005-S) Consult factory for custom colors</small>		