

TENON MOUNTED ARM

XMB

PROJECT NAME: _____

PROJECT TYPE: _____

FEATURES

Arm

Durable corrosion resistant, cast aluminum construction.

Finish

Electrostatically applied TGIC Polyester Powder Coat on substrate prepared with 20 PSI power wash at 140°F. Four step media blast and iron phosphate pretreatment for protection and paint adhesion. 400°F bake for maximum hardness and durability.



XMB

Patent pending

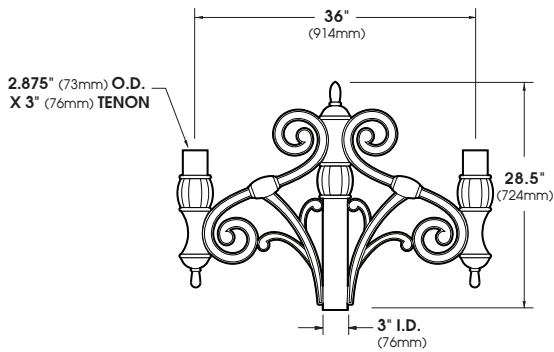

XMB-2-180
EPA = 2.18

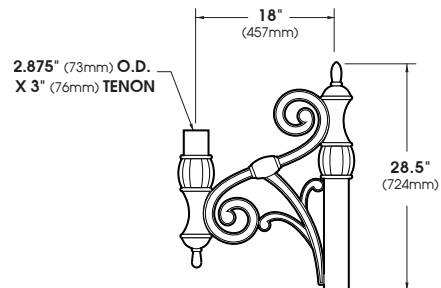

XMB-1
EPA = 1.34

SCALE: 1/2"=1'

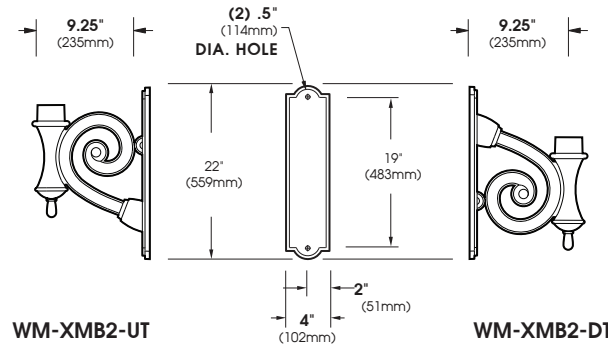
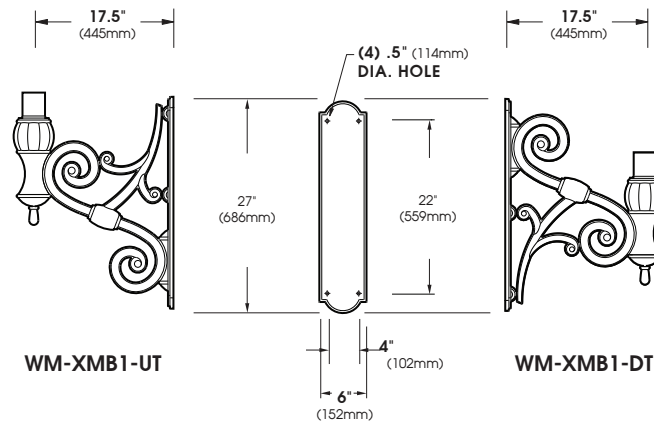

SCALE: 1/2"=1'

ORDERING INFORMATION

Spec/Order Example: XMB-4-120/RAL-8019-S

Configuration	<input type="checkbox"/> XMB-WM	<input type="checkbox"/> XMB-1	<input type="checkbox"/> XMB-2-180	<input type="checkbox"/> XMB-3-120	<input type="checkbox"/> XMB-4-90
Wall Mount Positioning	<input type="checkbox"/> WM-XMB1-UT	<input type="checkbox"/> WM-XMB1-DT	<input type="checkbox"/> WM-XMB2-UT	<input type="checkbox"/> WM-XMB2-DT	
Finish*	<input type="checkbox"/> Black RAL-9005-T	<input type="checkbox"/> White RAL-9003-T	<input type="checkbox"/> Grey RAL-7004-T	<input type="checkbox"/> Dark Bronze RAL-8019-T	<input type="checkbox"/> Green RAL-6005-T
					Premium Finishes <input type="checkbox"/> Rust <input type="checkbox"/> Patina Copper PC

*Standard texture finish. For smooth finish replace suffix "T" with suffix "S" (Example: RAL-9005-S)

Consult factory for custom colors