

TENON MOUNTED ARM

ATR/STR

PROJECT NAME: _____

PROJECT TYPE: _____

FEATURES

Arm

Aluminum: Extruded from 6063 alloy aluminum heat treated to produce a T6 temper.

Steel: Fabricated from high grade structural quality hot rolled carbon steel.

Finish

Electrostatically applied TGIC Polyester Powder Coat on substrate prepared with 20 PSI power wash at 140°F. Four step media blast and iron phosphate pretreatment for protection and paint adhesion. 400°F bake for maximum hardness and durability.



ATR/STR

Patent pending

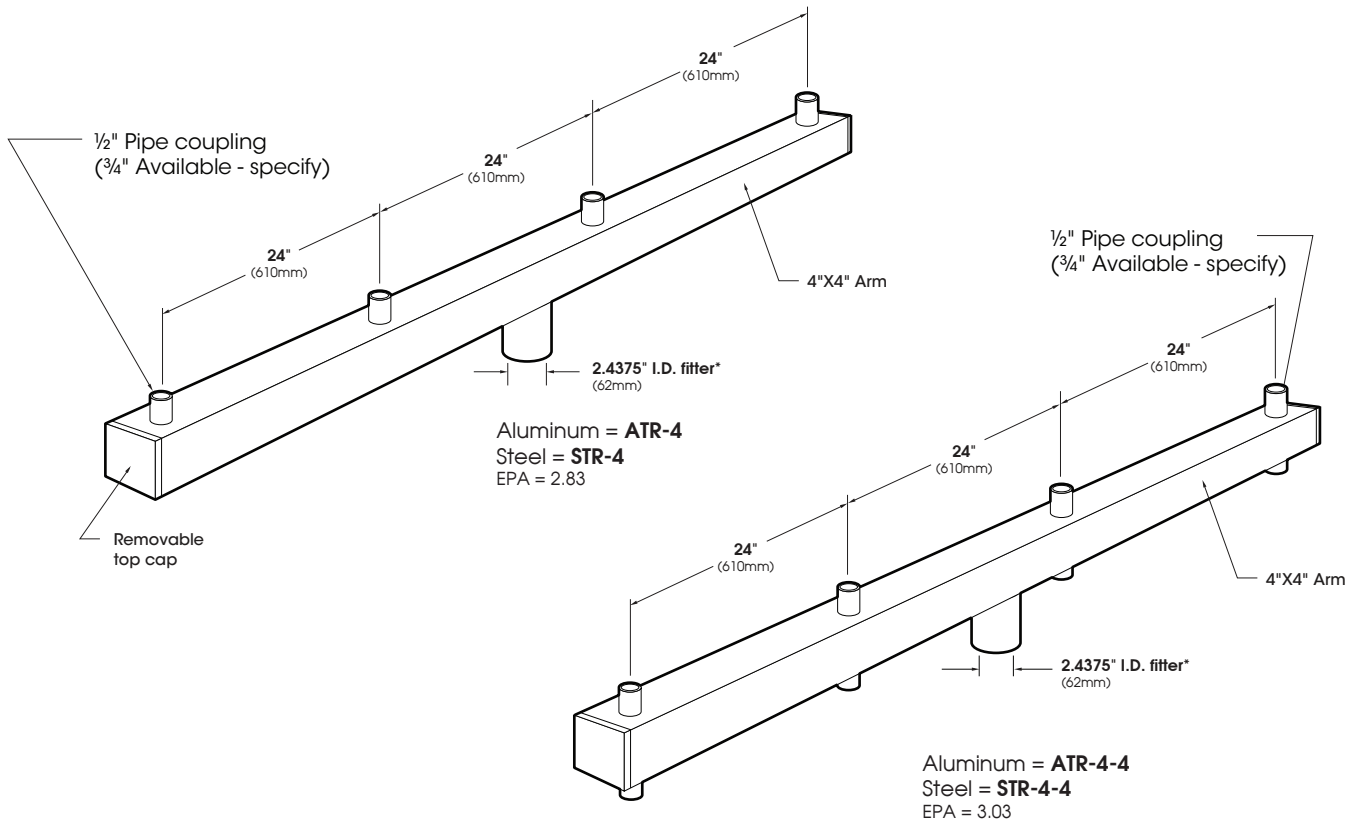

*Fitter accepts
2.375" O.D. X 4" tenon

SCALE: 1/2"=1'

ATR/STR

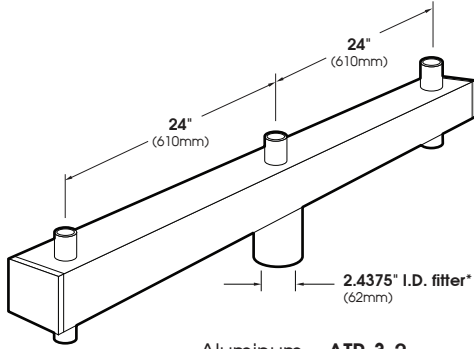

Aluminum = **ATR-3-2**
 Steel = **STR-3-2**
 EPA = 2.08

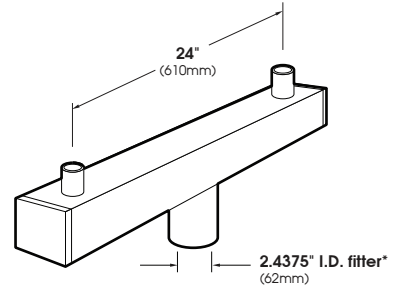





Aluminum = **ATR-2**
 Steel = **STR-2**
 EPA = 1.03

ORDERING INFORMATION

Spec/Order Example: STR-3-3/RAL-9005-S

Configuration

				
Upper Coupling only:	<input type="checkbox"/> ATR-WM-1 <input type="checkbox"/> STR-WM-1	<input type="checkbox"/> ATR-2 <input type="checkbox"/> STR-2	<input type="checkbox"/> ATR-3 <input type="checkbox"/> STR-3	<input type="checkbox"/> ATR-4 <input type="checkbox"/> STR-4
Upper and Lower Coupling only:	<input type="checkbox"/> ATR-WM-1-1 <input type="checkbox"/> STR-WM-1-1	<input type="checkbox"/> ATR-2-2 <input type="checkbox"/> STR-2-2	<input type="checkbox"/> ATR-3-3 <input type="checkbox"/> STR-3-3	<input type="checkbox"/> ATR-4-4 <input type="checkbox"/> STR-4-4

Finish*

- Black
RAL-9005-T
- White
RAL-9003-T
- Grey
RAL-7004-T
- Dark Bronze
RAL-8019-T
- Green
RAL-6005-T

*Aluminum standard texture finish
 Steel supplied with smooth finish
 For smooth finish replace suffix "T" with suffix "S"
 (Example: RAL-9005-S)
 Consult factory for custom colors